

# Power Panel for SDN

Item #: 1870259



## OVERVIEW:

The **Power Panel for SDN** is a SDN bus distribution component used to add 10 isolated motor ports and two isolated device ports to an SDN bus segment. The isolated motor ports support up to 240 feet of power and data wiring to individual low voltage intelligent motors. The in-wall or on-wall mountable enclosure offers separated line and low voltage areas for ease of installation. This product could be used in small SDN systems with two control devices and 10 individual motors as a stand alone solution.

## SOMFY DIGITAL NETWORK SYSTEM OVERVIEW:

**Somfy Digital Network (SDN)** is Somfy's intelligent wired shading network. An SDN system is comprised of bus distribution devices that create a network for user interfaces, motorized applications and sensors to be connected. SDN is scalable, and suitable for both small and large projects, and the same components are used whether an SDN system remains standalone, integrated into third party automation systems, or with Somfy's animeo® IP automated total solar management system.

## FEATURES SUMMARY:

- 10 isolated low voltage motor ports
- 2 isolated device ports
- Includes bus segment status LEDs for:
  - Power
  - Communication
  - End of line notification
- Protects system components from miswire
- Automatic segment termination
- Can mount on-wall or in-wall (between studs)
- Separated line and low voltage areas
- Front cover includes a keyed lock

## CABLE PINOUTS:

### SDN INPUT

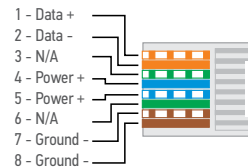

### MOTOR INPUT

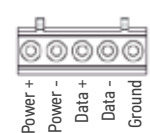

## WHAT'S IN THE BOX:

- Power Panel
- Instructions

## TECHNICAL SPECIFICATIONS:

- Input: 120V AC, 7.2A
- Motor Output: 24V DC 2A per motor output
- SDN Power Units: Consumes 0 units on bus, supplies 10 units per device port
- Material: Steel Enclosure
- Dimensions: 18.9" L 14.4" W x 3.5" H (Inner)
- Dimensions: 21.3" L 16.4" W x 3.8" H (Inner with door)
- Maximum Wiring Distance
  - To motors:
    - Up to 240ft with 14AWG wire per motor port
    - Up to 150ft with 16AWG wire per motor port
    - Up to 100ft with 18AWG wire per motor port
  - To devices:
    - Up to 800ft per device port
- Operating Temperature Range: Ambient temperature
- Shipping Weight: 24 lbs.
- Indoor use only



## CONNECTIONS AND INDICATORS:

ELEMENT	FUNCTION
1 <b>Power Input</b>	Flying leads with push-in conduit connection located on the bottom right corner of the panel. Supports solid 12 & 14 AWG wiring.
2 <b>SDN Bus Input</b>	Input for Bus signals
3 <b>SDN Bus Output</b>	Output for Bus signals
4 <b>Isolated Motor Port</b>	10 low voltage motors to SDN network
5 <b>Device Port</b>	2 SDN devices to the SDN network (max. 800 ft. each)

LED Indicators				
LABEL	ELEMENT	COLOR	FUNCTION ON	FUNCTION OFF
P	<b>Bus Power</b>	Green	Power	No Power
L	<b>Bus Low (Bus Data)</b>	Green	No Data	Data
H	<b>Bus High</b>	Green	Data	No Data
E	<b>End of Bus</b>	Yellow	End of bus	Not End of bus
D	<b>Device LED</b>	Green	Device port powered	Device port not powered

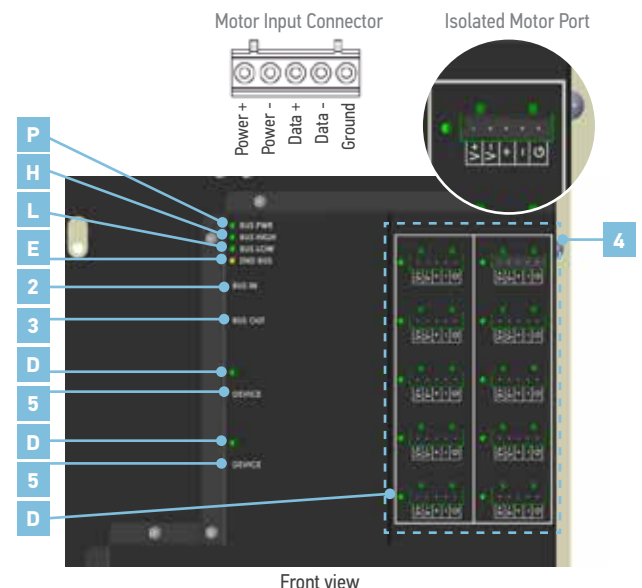

## DIMENSIONS:

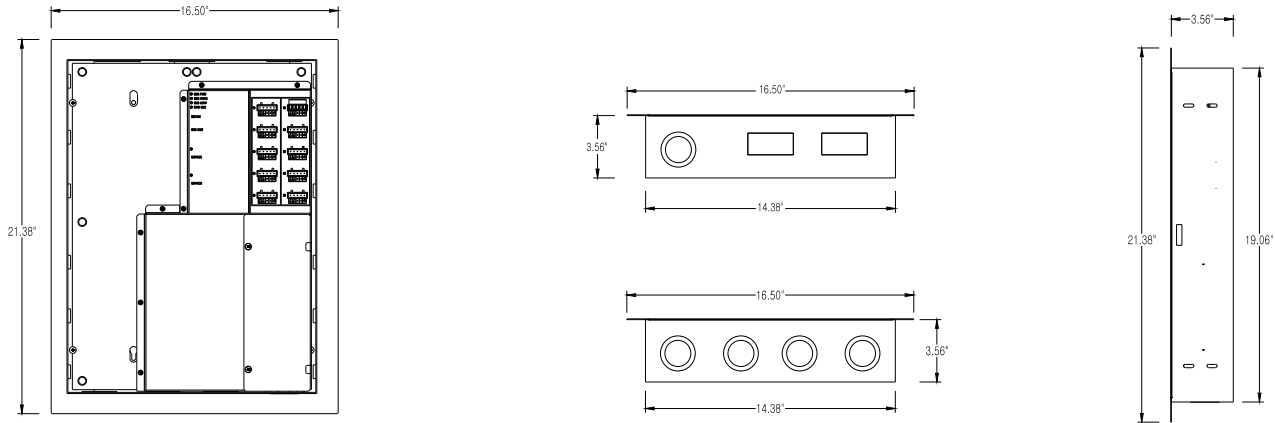

## BEST WIRING PRACTICES

The diagram shown below is meant for illustrative purposes to show the connections from product to product. This device could be used in other configurations than shown below.

- Adds 10 isolated motor ports and 2 isolated device ports to a system.
- Motor wiring distance up to 240 ft. using 14 AWG wire.
- Maximum 800 ft. per isolated device port.

