

Techstyle® E acoustical ceiling panels feature a clean, white aesthetic and excellent broadband noise reduction.

© Bob Perzel

Project: KFC Yum! Center, Louisville, KY; Techstyle® E

KEY FEATURES

- Proprietary formaldehyde-free fiberglass composite construction
- Monolithic appearance - large format panels, semi-concealed suspension, nominal 1/4" reveals
- Convenient swing-down access to the plenum
- Trims are engineered for fast installation of Techstyle®
- High light reflectance: 81% (LR1) ASTM E1477
- High acoustical performance: NRC of 0.85 and SAA of 0.86
- Enhanced soiling resistance and clean-ability
- Formaldehyde free
- Class A Fire Rating, per ASTM E84
- GREENGUARD Gold Certified

COLORS & FINISHES

Available in White only.



White

TYPICAL ISOMETRICS

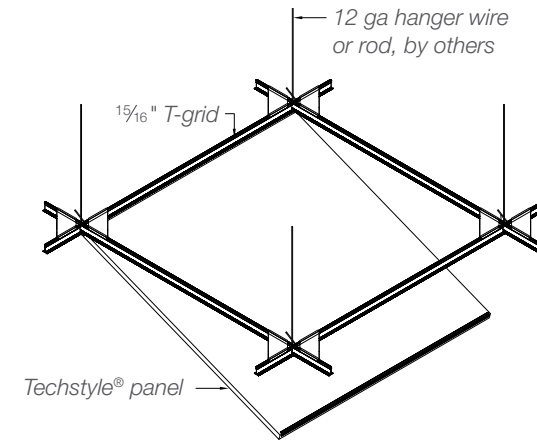

TYPICAL SECTION - TRIMS

A-mount perimeter

Wall trims

Floating trims

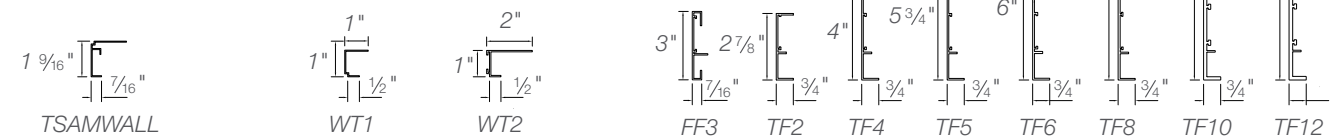

PANEL SIZES

Width x Length

24" x 6"	24" x 24"	24" x 42"	24" x 48"
24" x 54"	24" x 60"	24" x 66"	24" x 72"
24" x 78"	24" x 84"	24" x 90"	24" x 96"
30" x 6"	30" x 30"	30" x 60"	30" x 72"
48" x 6"	48" x 24"	48" x 42"	48" x 48"
48" x 54"	48" x 60"	48" x 66"	48" x 72"

ACOUSTICS

Techstyle®'s honeycomb design absorbs both high and low frequencies at an impressive level, providing superior acoustical performance, no matter the frequency. NRC 0.85 (ASTM C 423) SAA 0.86 (ASTM C 423).

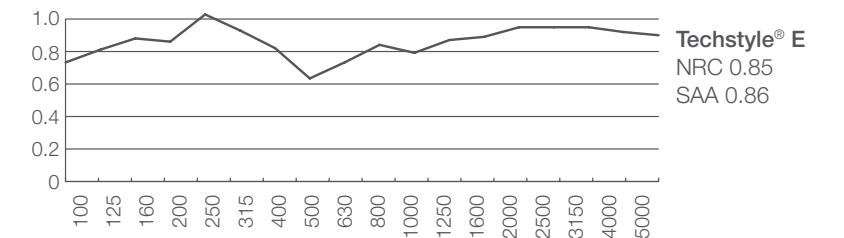

PHYSICAL DATA

- Surface Finish:** Acoustical Coating
- Light Reflectance:** 81% (LR1) ASTM E1477
- Surface Burning:** Class A (ASTM E84)
 - Flame Spread Index ≤ 10
 - Smoke Index ≤ 10
- Acoustical Ratings – NRC:** 0.85 (ASTM C 423)
- Acoustical Ratings – CAC:** 17 w/no backer, (ASTM E1414)
- Moisture Resistance:** Resistant to 95% humidity in 104 temperature
- Fungal Resistance:** Resistant (ASTM C1338)
- Weight:** 0.30 lbs. per sq. ft.
- Warranty:** 10 year limited
- ICC:** Approval (ESR-2123)

BIM

REVIT files available for BIM contributions, see website for details.

LEED V4 CREDITS

- EA:** Optimize Energy Performance
- MR:** Building Product Disclosure
- EQ:** Low-Emitting Materials
- EQ:** Indoor Air Quality Assessment
- EQ:** Daylight
- EQ:** Acoustic Performance

CERTIFICATIONS

GREENGUARD Gold Certified
HPDs & EPDs – available upon request