



Most Widely Accepted and Trusted

ICC-ES Evaluation Report

ESR-2123

ICC-ES | (800) 423-6587 | (562) 699-0543 | www.icc-es.org

Reissued 11/2017
This report is subject to renewal 11/2019.

DIVISION: 09 00 00—FINISHES
SECTION: 09 51 23—ACOUSTICAL TILE CEILINGS

REPORT HOLDER:

HUNTER DOUGLAS SPECIALTY PRODUCTS INC.

**ONE HUNTER DOUGLAS CIRCLE
THORNTON, COLORADO 80241**

EVALUATION SUBJECT:

TECHSTYLE® AND TECHSTYLE® E ACOUSTICAL CEILING TILES



Look for the trusted marks of Conformity!

“2014 Recipient of Prestigious Western States Seismic Policy Council (WSSPC) Award in Excellence”



ICC-ES Evaluation Reports are not to be construed as representing aesthetics or any other attributes not specifically addressed, nor are they to be construed as an endorsement of the subject of the report or a recommendation for its use. There is no warranty by ICC Evaluation Service, LLC, express or implied, as to any finding or other matter in this report, or as to any product covered by the report.

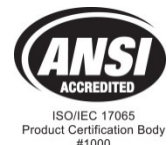

ICC-ES Evaluation Report

ESR-2123

Reissued November 2017

This report is subject to renewal November 2019.

www.icc-es.org | (800) 423-6587 | (562) 699-0543

A Subsidiary of the International Code Council®

DIVISION: 09 00 00—FINISHES

Section: 09 51 23—Acoustical Tile Ceilings

REPORT HOLDER:

HUNTER DOUGLAS SPECIALTY PRODUCTS, INC.

ONE HUNTER DOUGLAS CIRCLE

THORNTON, COLORADO 80241

(720) 872-7800

www.hdtechstyle.com

techstyle.cs@hunterdouglas.com

EVALUATION SUBJECT:

**TECHSTYLE® AND TECHSTYLE® E ACOUSTICAL
CEILING TILES**

1.0 EVALUATION SCOPE

Compliance with the following codes:

- 2006 *International Building Code*® (IBC)
- 2006 *International Mechanical Code*® (IMC)

Properties evaluated:

- Interior finish classification
- Thermal stability
- Structural

2.0 USES

Techstyle® and Techstyle® E acoustical ceiling tiles are used as Class A interior finish nonstructural ceiling tiles in nonfire-resistance-rated suspended ceiling systems. The tiles may be exposed within a return air plenum in accordance with IMC Section 602.2.1.

3.0 DESCRIPTION

Techstyle® and Techstyle® E acoustical ceiling tiles are produced from two glass fiber sheets laminated to glass fiber strips that form the core of the tile, and a mineral-coated fiberglass or polyester sheet that is laminated to the exposed surface of the tile. The tiles are nominally 1¹/₈ inches (28.5 mm) thick and are available in various sizes. The tiles weigh approximately 0.2 pound per square foot (1.0 kg/m²). Panel ends have a factory-installed continuous rigid PVC clip that is used to connect the tiles to the ceiling grid system; refer to Figures 1 and 2. The panels are also available without the PVC clips for use with

lay-in ceiling grid systems; refer to Figure 3. The tiles have a Class A interior finish, a flame-spread index not greater than 25, and a smoke-developed index not greater than 50 when tested in accordance with ASTM E84.

4.0 INSTALLATION

Installation of the Techstyle® and Techstyle® E acoustical ceiling tiles must comply with this report and the manufacturer's published installation instructions. The manufacturer's published installation instructions must be available at the jobsite at all times during installation. In the event of a conflict between this report and the manufacturer's published installation instructions, the more restrictive governs. The tiles must be installed in suspended ceiling systems complying with Section 803.9 of the IBC.

5.0 CONDITIONS OF USE

The Hunter Douglas Specialty Products, Inc., Techstyle® and Techstyle® E acoustical ceiling tiles described in this report comply with, or are suitable alternatives to what is specified in, those codes listed in Section 1.0 of this report, subject to the following conditions:

- 5.1** Installation complies with this report, the manufacturer's published installation instructions and the applicable code.
- 5.2** The tiles are limited to use in nonfire-resistance-rated ceiling assemblies of all types of construction.

6.0 EVIDENCE SUBMITTED

- 6.1** Quality documentation.
- 6.2** Report containing results of testing performed in accordance with ASTM E84.
- 6.3** Report on stability: panels to remain in place at a room temperature of 200°F (93°C) for 30 minutes, to show compliance with Section 803.3 of the IBC; and structural load testing of PVC clips.

7.0 IDENTIFICATION

Packaging of the Techstyle® and Techstyle® E acoustical ceiling tiles bears a stamp with the manufacturer's name (Hunter Douglas Specialty Products, Inc.) and address, the product name, and the evaluation report number (ESR-2123). Each tile is identified on the back with the manufacturer's name (Hunter Douglas Specialty Products, Inc.), the product name and a production code.

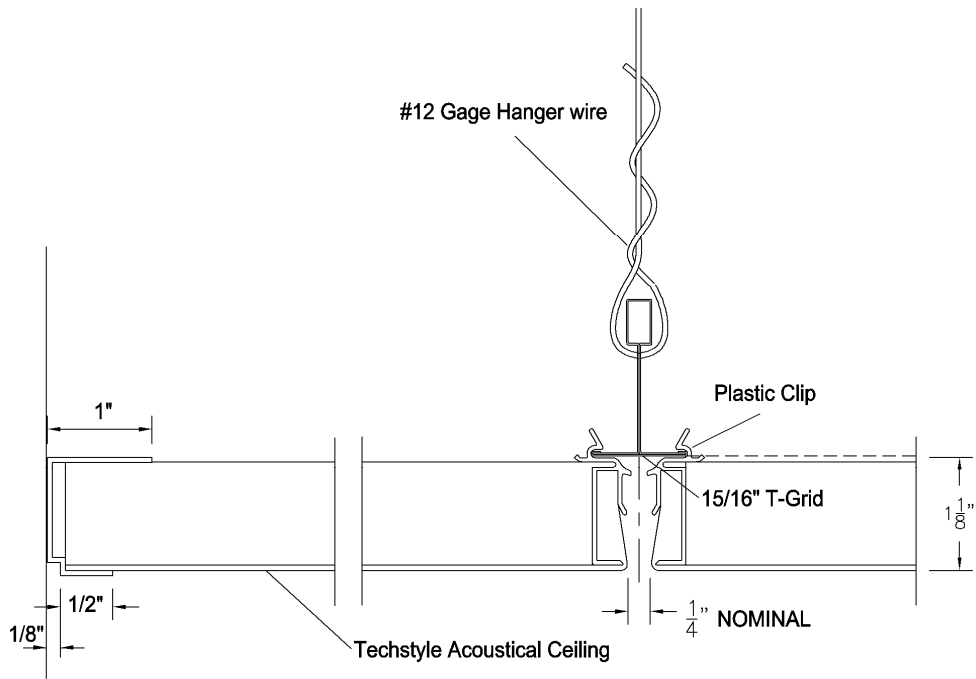

FIGURE 1—TYPICAL CLIPPED INSTALLATION

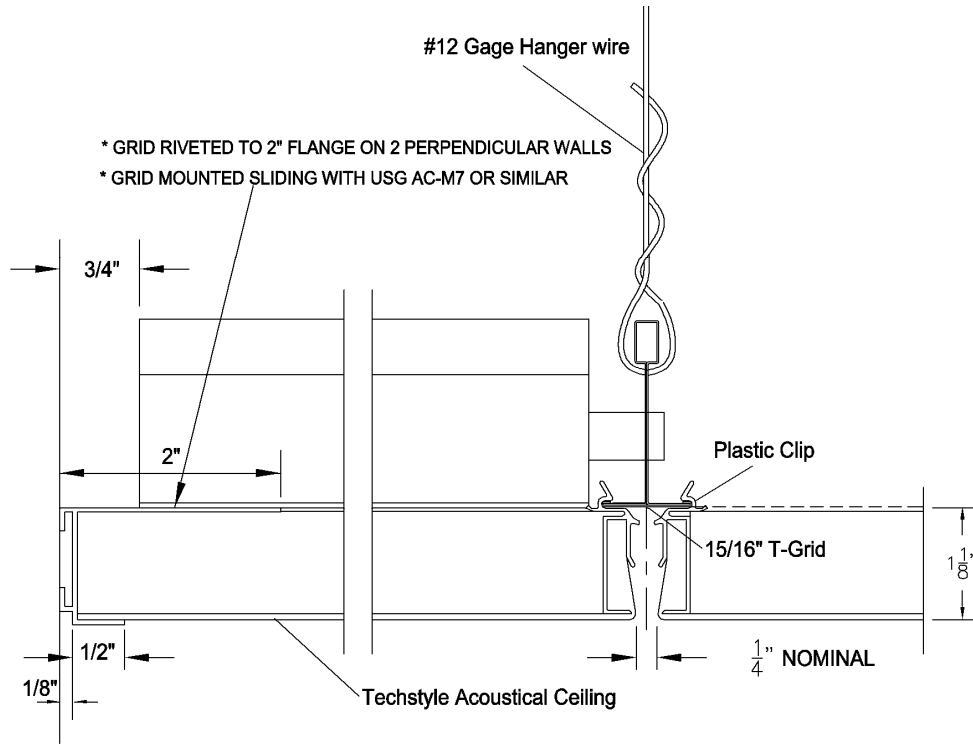

FIGURE 2—SEISMIC CLIPPED INSTALLATION

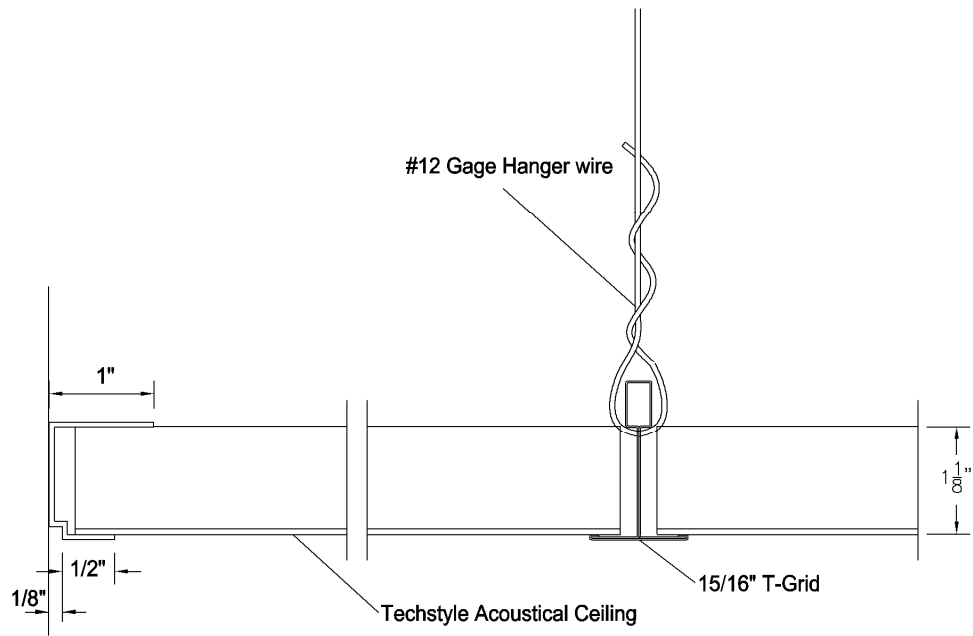

FIGURE 3—TYPICAL LAY-IN INSTALLATION