

METAL CEILINGS

PLANK & TILE
TORSION SPRING

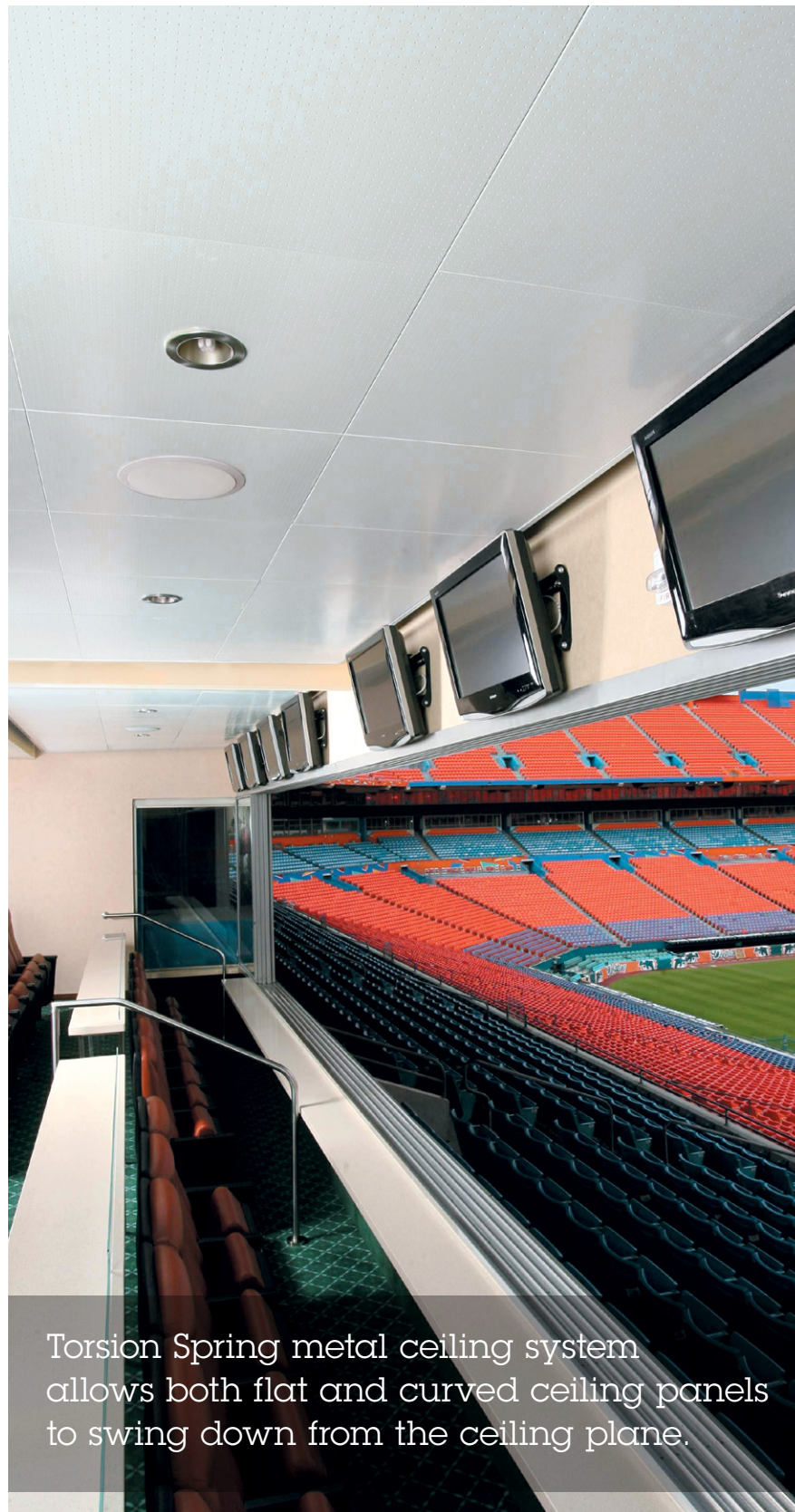

Torsion Spring metal ceiling system allows both flat and curved ceiling panels to swing down from the ceiling plane.

KEY FEATURES

- Two panel size sets:
 - 6" to 36" width up to 120" long
 - 48" width up to 48" long
- Swing-down feature allows point-access and 100% access to plenum
- Square-edge design
- Waste reduction with factory fabricated dimensional material
- Downweight: reduce dead load with lightweight aluminum
- Interior and exterior applications
- Compatible with industry standard lighting, HVAC, speaker, fire safety, and security services

COLORS & FINISHES

Standard colors Natural and Cotton White shown. Client-specific colors available. Minimum quantities may apply. Colors are for illustrative purposes. See page 178 for all colors and finishes.

Standard colors

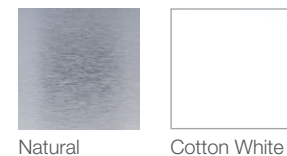

Custom colors



Custom

Woodwright™ finishes include our painted wood-look finish, real wood veneers and laminated wood-look films. See page 180 for all finishes.

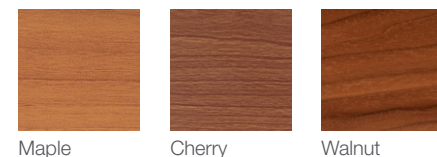

TYPICAL ISOMETRICS

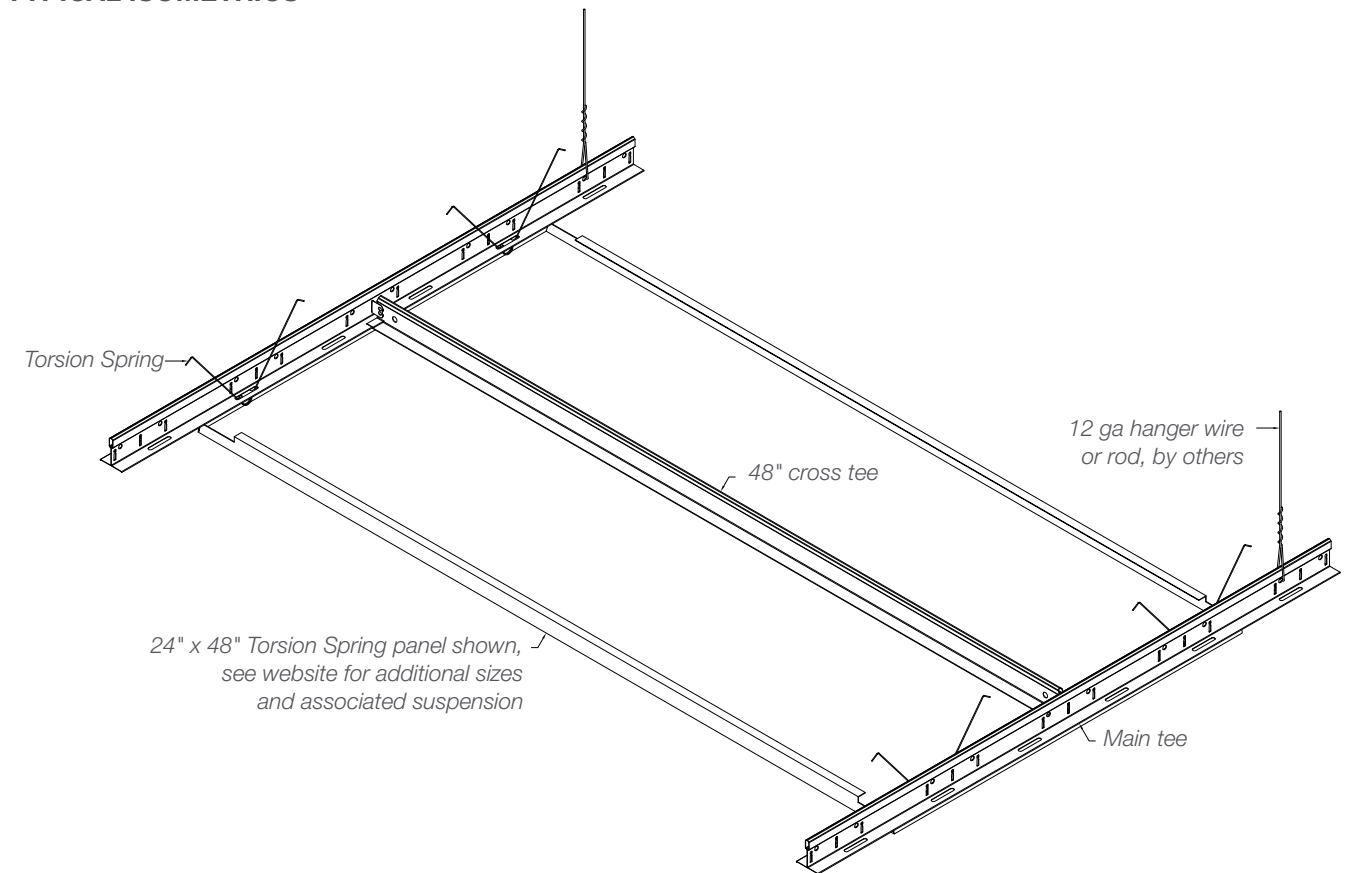

PERFORATION PATTERNS

Standard patterns shown. See page 186 to see all perforation patterns. Scale shown: 1:1, unless otherwise noted.

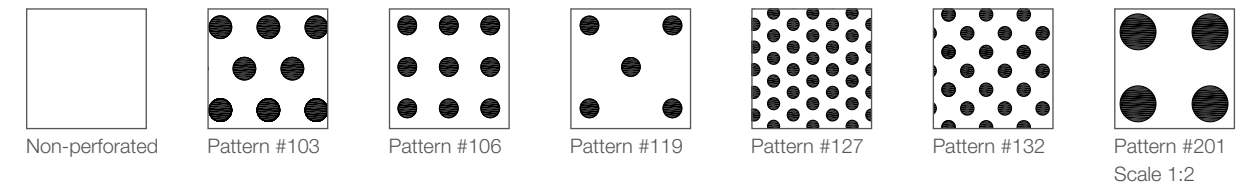

PHYSICAL DATA

- Substrate:** Aluminum
- Warranty:** 1 year
- Seismic rating:** Zones A,B,C,D,E,F
- Fire rating:** Class A Fire Rated per ASTM E84
 - Painted or anodized metal: Flame spread: ≤ 25, Smoke ≤ 50
 - Film on metal: Flame spread: ≤ 25, Smoke ≤ 50
 - Wood veneer on metal: Flame spread: ≤ 25, Smoke ≤ 55 (for interior applications)
- Weight:** Varies 1.0 – 1.5 lbs./sq.ft.
- Wind load:** Per code (for exterior applications)
- Recycled content:** Up to 85%
- Light reflectance (LR) Coefficient per ASTM E1264 & ASTM E1477:**
 - Cotton White: LR = 0.81
- Acoustical ratings – NRC:** See page 190

BIM

REVIT files available for BIM contributions, see website for details.

LEED V4 CREDITS

- EA:** Optimize Energy Performance
- MR:** Building Product Disclosure
- EQ:** Low-Emitting Materials
- EQ:** Indoor Air Quality Assessment
- EQ:** Daylight
- EQ:** Acoustic Performance

CERTIFICATIONS

GREENGUARD Gold Certified
HPDs & EPDs – available upon request