

METAL CEILINGS

EXTERIOR – LINEAR
150F

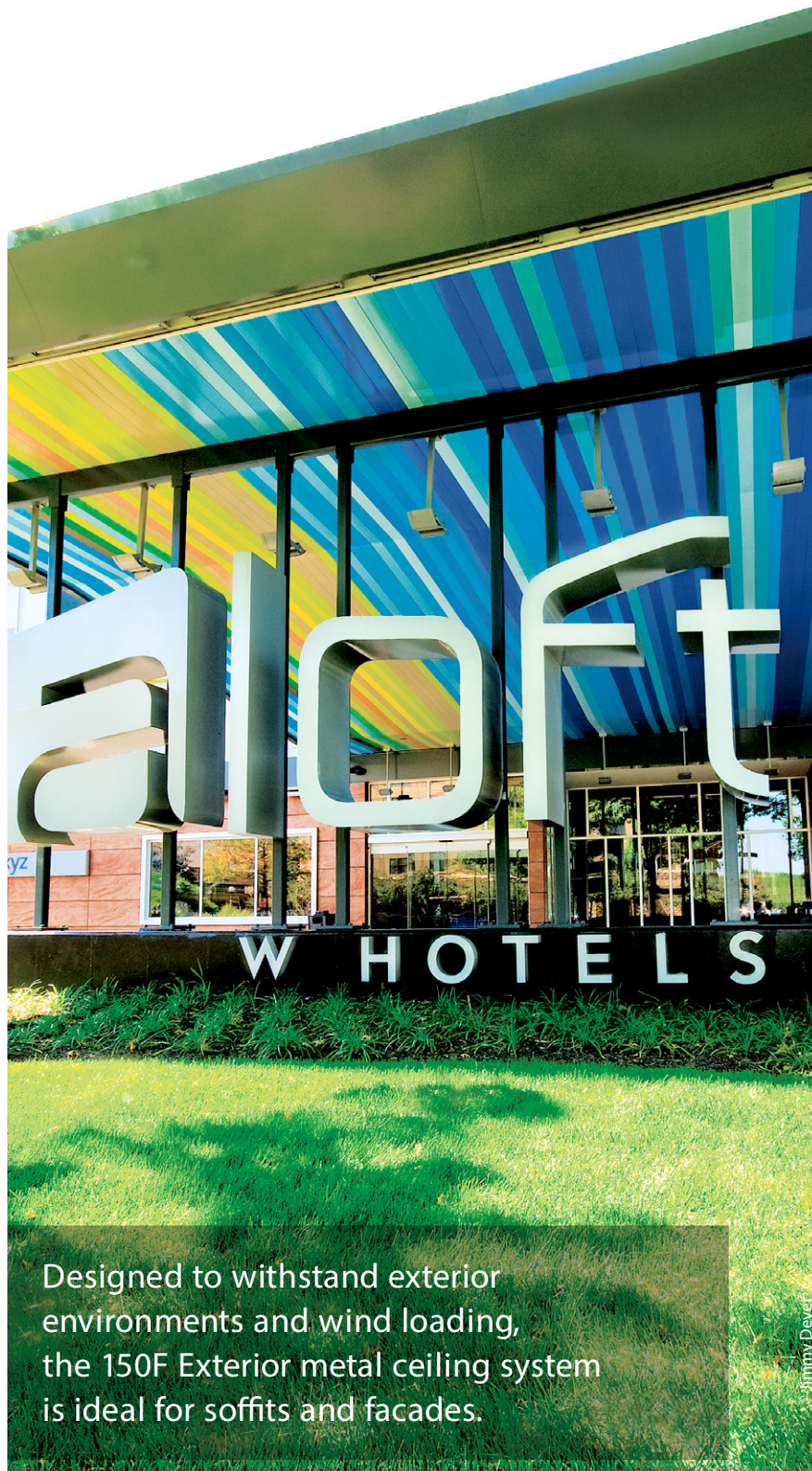

Designed to withstand exterior environments and wind loading, the 150F Exterior metal ceiling system is ideal for soffits and facades.

KEY FEATURES

- Panel width: 6" nom. [150 mm]
- Panel lengths: 3' to 20'
- Panel depth: 1 1/16"
- Waste reduction with factory fabricated dimensional material
- Downweight: reduce dead load with lightweight aluminum
- Interior and exterior applications
- Compatible with industry standard lighting, HVAC, speaker, fire safety, and security services
- Perforated panels available for ventilation
- Factory assembled access doors available
- Miami-Dade County, FL NOA No. 14-1222.04 (expires March 19, 2020)

COLORS & FINISHES

Standard 150F colors Natural, Cotton White, Luxacote Natural and Luxacote Lighthouse White shown. Client-specific colors available. Minimum quantities may apply. Colors are for illustrative purposes. See page 178 for all colors and finishes.

Standard colors



Custom colors



Woodwright™ finishes use our painted wood-look finish. See page 180 for all finishes.

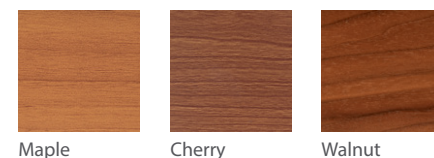

TYPICAL SECTIONS

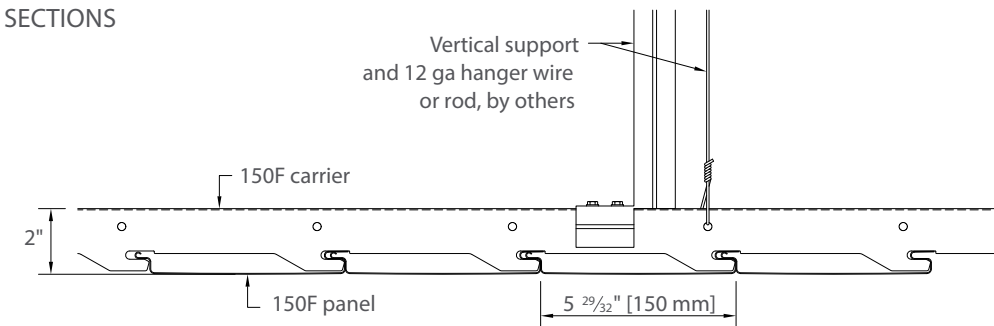

TYPICAL ISOMETRICS

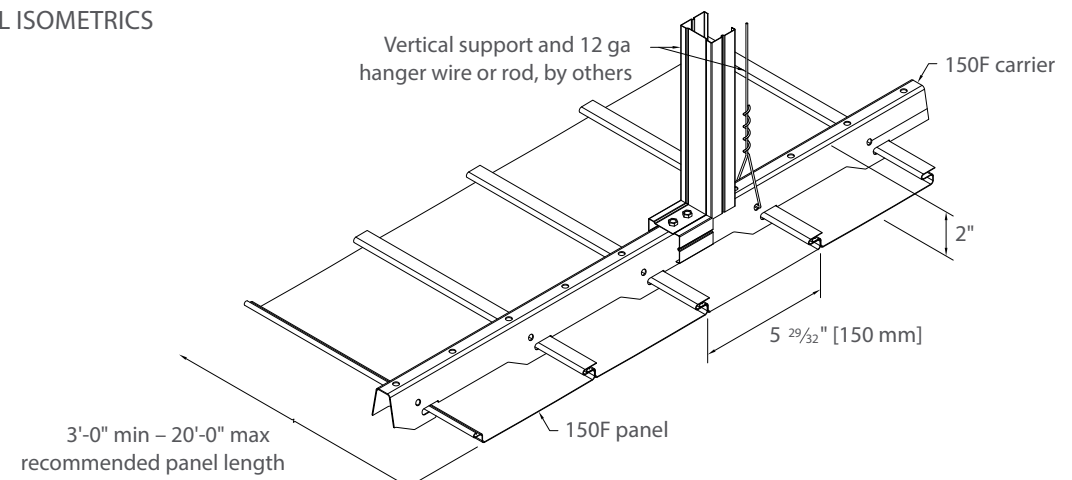

PERFORATION PATTERNS

Standard patterns shown. Scale shown: 1:1, unless otherwise noted.

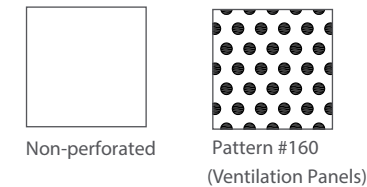

PHYSICAL DATA

- Substrate: Aluminum
- Warranty: 1 year
- Seismic rating: Zones A,B,C,D,E,F
- Fire rating: Class A Fire Rated per ASTM E84
 - Painted or anodized metal: Flame spread: ≤ 25, Smoke ≤ 50
- Weight: 0.75 lbs./sq.ft.
- Wind load: Per code
- Designed and tested in accordance with the requirements of the Florida Building Code 5th edition (2014), including the High Velocity Hurricane Zone (HVHZ) provisions and Miami-Dade requirements.
- Miami-Dade County, Florida NOA No. 14-1222.04 (expires March 19, 2020)
- Recycled content: Up to 92%
- Light reflectance (LR) Coefficient per ASTM E1264 & ASTM E1477:
 - Cotton White: LR = 0.81

BIM
REVIT files available for BIM contributions, see website for details.

LEED V4 CREDITS

- EA: Optimize Energy Performance
- MR: Building Product Disclosure
- EQ: Low-Emitting Materials
- EQ: Indoor Air Quality Assessment
- EQ: Daylight

CERTIFICATIONS
GREENGUARD Gold Certified
HPDs & EPDs – available upon request