

WOODWRIGHT™
CEILINGS

PLANK & TILE
TORSION SPRING

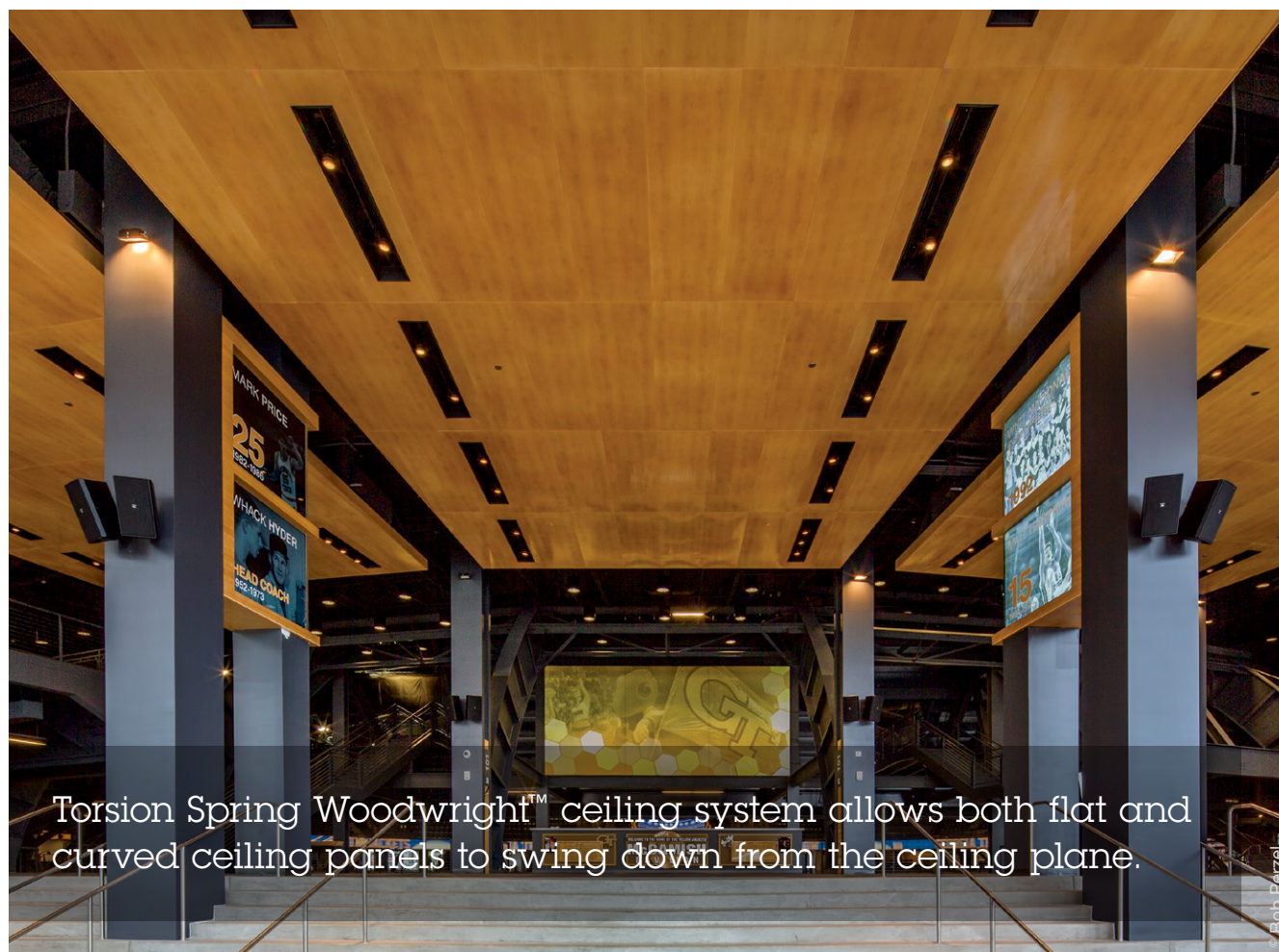

Torsion Spring Woodwright™ ceiling system allows both flat and curved ceiling panels to swing down from the ceiling plane.

Project: McCamish Pavilion at Georgia Tech, Atlanta, GA; Woodwright™ Torsion Spring

TYPICAL ISOMETRICS

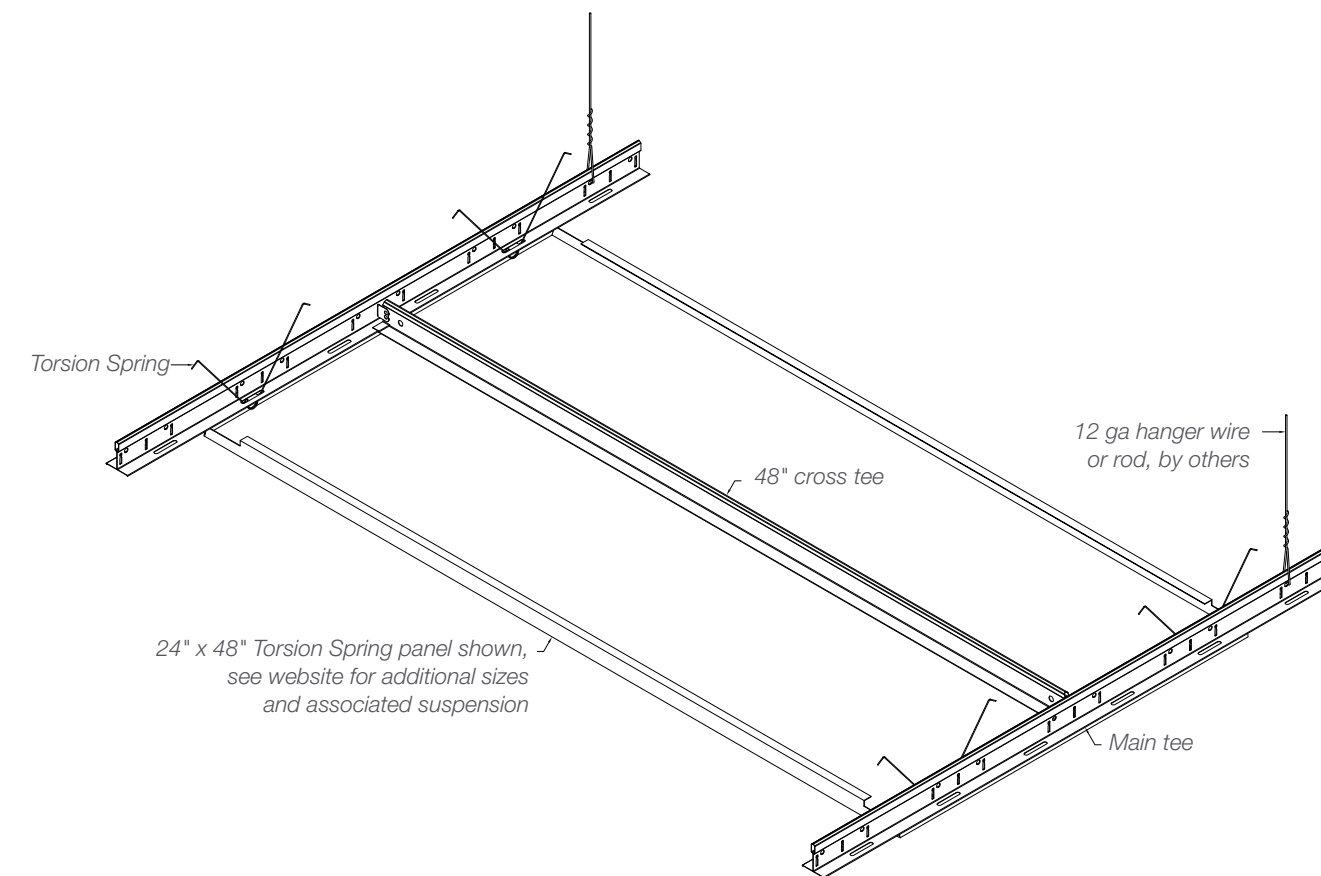

24" x 48" Torsion Spring panel shown, see website for additional sizes and associated suspension

PERFORATION PATTERNS

Please consult Hunter Douglas for perforation options.

PHYSICAL DATA

- Substrate:** Aluminum
- Warranty:** 1 year
- Seismic rating:** Zones A,B,C,D,E,F
- Fire rating:** Class A Fire Rated per ASTM E84
 - Painted or anodized metal: Flame spread: ≤ 25, Smoke ≤ 50
 - Film on metal: Flame spread: ≤ 25, Smoke ≤ 50
 - Wood veneer on metal: Flame spread: ≤ 25, Smoke ≤ 55 (for interior applications)
- Weight:** Varies 1.1 – 1.6 lbs./sq.ft.
- Wind load:** Per code (for exterior applications)
- Recycled content:** Up to 85%
- Light reflectance:** Varies with finish
- Acoustical ratings – NRC:** See page 190

BIM
REVIT files available for BIM contributions, see website for details.

LEED V4 CREDITS

- EA:** Optimize Energy Performance
- MR:** Building Product Disclosure
- EQ:** Low-Emitting Materials
- EQ:** Indoor Air Quality Assessment
- EQ:** Acoustic Performance

CERTIFICATIONS
GREENGUARD Gold Certified
FSC chain of custody veneers available
HPDs & EPDs – available upon request

KEY FEATURES

- Two panel size sets:
 - 6" to 36" width up to 120" long
 - 48" width up to 48" long
- Swing-down feature allows point-access and 100% access to plenum
- Square-edge design
- Waste reduction with factory fabricated dimensional material
- Downweight: reduce dead load with lightweight aluminum
- Interior and exterior applications
- Compatible with industry standard lighting, HVAC, speaker, fire safety, and security services

COLORS & FINISHES

Woodwright™ finishes include our painted wood-look finish, real wood veneers and laminated wood-look films. See page 180 for all finishes.

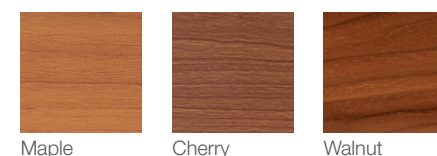

Standard colors Natural and Cotton White shown. Client-specific colors available. Minimum quantities may apply. Colors are for illustrative purposes. See page 178 for all colors and finishes.

