

METAL CEILINGS

PLANK & TILE
GLADIUS™

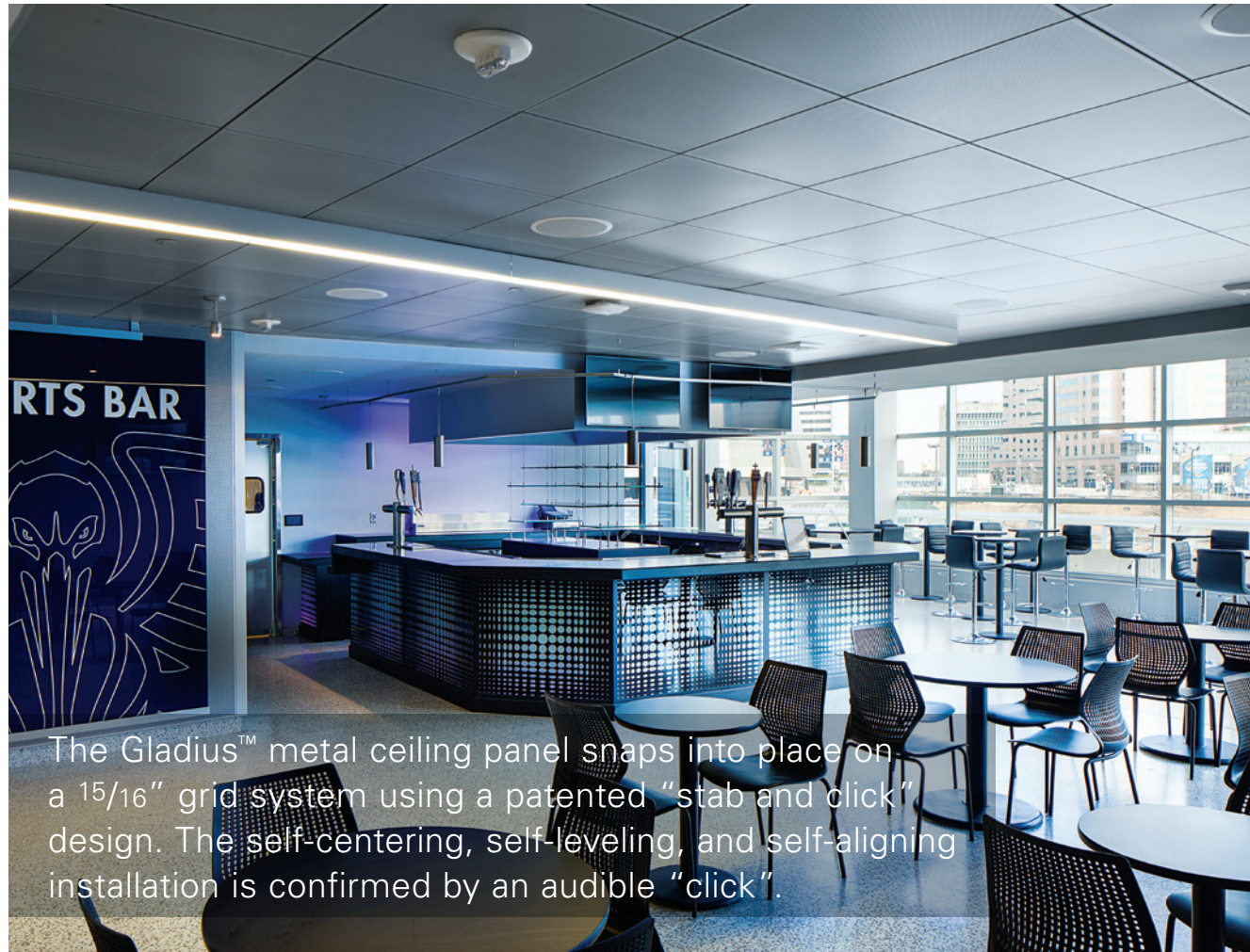

The Gladius™ metal ceiling panel snaps into place on a 15/16" grid system using a patented "stab and click" design. The self-centering, self-leveling, and self-aligning installation is confirmed by an audible "click".

Project: Smoothie King Center, New Orleans, LA; Gladius™ Photo credit: Jeffrey Johnson

KEY FEATURES

- Panel size: 24" x 24"
- Square-edge design
- Waste reduction with factory fabricated dimensional material
- Downweight: reduce dead load with lightweight aluminum
- Easy plenum access
- Interior and exterior applications
- Compatible with industry standard lighting, HVAC, speaker, fire safety, and security services

TYPICAL ISOMETRICS

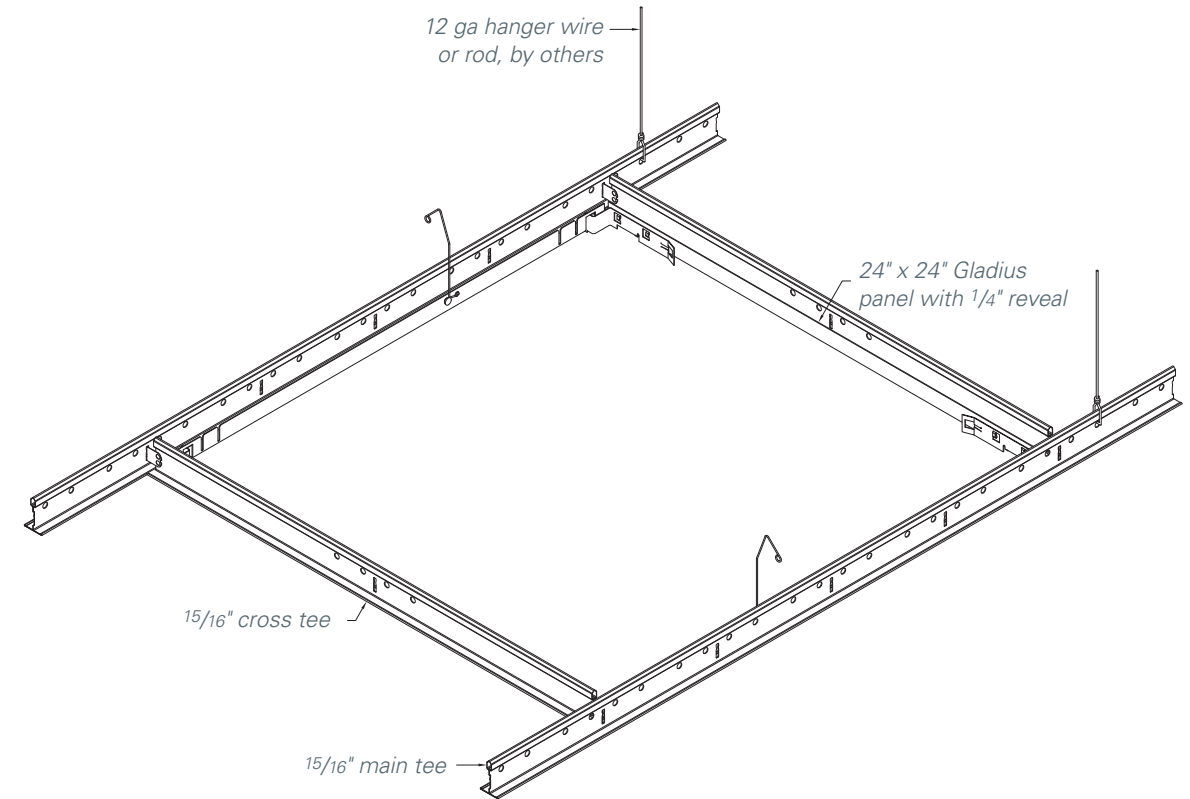

PERFORATION PATTERNS

Standard patterns shown. See page 238 to see all perforation patterns. Scale shown: 1:1, unless otherwise noted.

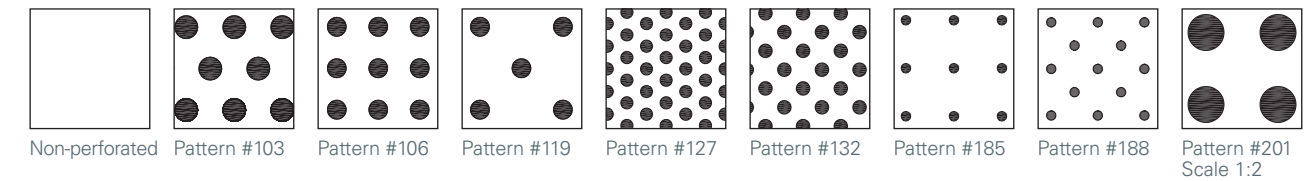

PHYSICAL DATA

Substrate: Aluminum
Warranty: 1 year
Seismic rating: Zones A,B,C,D,E,F
Fire rating: Class A Fire Rated per ASTM E84
 – Painted or anodized metal: Flame spread: ≤ 25, Smoke ≤ 50
Weight: Varies 1.1 lbs./sq.ft.
Wind load: Per code (for exterior applications)
Recycled content: Up to 92%
Light reflectance (LR) Coefficient per ASTM E1264 & ASTM E1477:
 – Varies with finish
 – Cotton White: LR = 0.81
Acoustical ratings – NRC: See page 240

BIM

REVIT files available for BIM contributions, see website for details.

LEED V4 CREDITS

EA: Optimize Energy Performance
 MR: Building Product Disclosure
 EQ: Low-Emitting Materials
 EQ: Indoor Air Quality Assessment
 EQ: Daylight
 EQ: Acoustic Performance

CERTIFICATIONS

GREENGUARD Gold Certified
 HPDs & EPDs – available upon request

METAL CEILINGS

PLANK & TILE
GLADIUS™

COLORS & FINISHES

Hunter Douglas offers a wide choice of colors and finishes. Some colors and finishes carry a premium price over manufacturer's standard colors. Custom color matching is available upon request. Please contact Hunter Douglas at 800-366-4327 for minimum quantities and lead times. To request samples, contact us at ceiling.samples@hunterdouglas.com. See website for the most up to date information. Colors are for illustration purposes only.

STANDARD PAINT COLORS



CUSTOM COLORS

Premium custom colors.

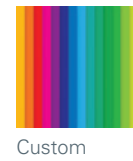

WHITE FINISH OPTIONS

Powder-coat paint finish for Arctic White #1015P (Gloss 10-20); Crystalline White #1050P (Gloss 45-55); Supernova White #1085P (Gloss 80-90)

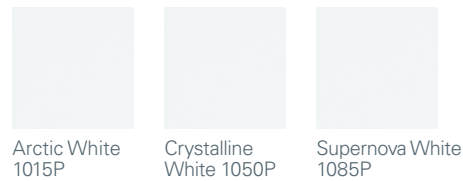

PERFORMANCE WHITE PAINT FINISH

Powder-coat paint finish offering LRV 96; non-glare, 3% low gloss finish. Certified by: Applied Technical Services, Inc. Test Report No. D233185. Test reports available by request.

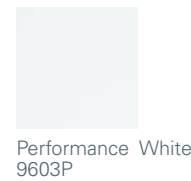

BLACK FINISH OPTIONS

Powder-coat paint finish for Starless Black #5000P (Matte); Raven Black #5030P (Gloss 25-35); Sable Black #5060P (Gloss 65-75); Wet Glass Black #5095P (Gloss 90-95)

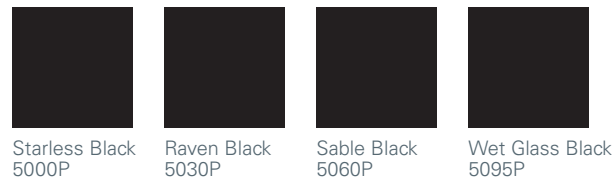

DECORATED WOOD-LOOK OPTIONS

Powder-coat paint finish (interior and exterior). Formaldehyde-free, Class A composite panel. This finish is recommended for exterior conditions.

