

# H282 2" Aluminum Horizontal Blinds



Our Model H282 aluminum blind with 42mm tape spacing and de-Light™ feature is an optimal fit for larger spaces where light control is most important, including auditoriums, conference rooms, and more.

## KEY FEATURES

- 1 1/2" x 2 1/4" x .024" Headrail
- Heat-treated, spring-tempered aluminum slats
- Slats contain 95% recycled aluminum content and are GREENGUARD GOLD Indoor Air Quality Certified®
- de-Light™ feature eliminates light leakage
- Ladder tapes in vinyl, polyester, or fabric
- Cord stop to single pull cord
- Closed oval bottom rail
- Lifetime Guarantee



125 Bright White

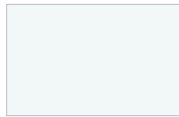

885 Flex White

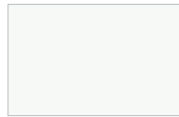

110 Gloss White



974 Pearl



002 Alabaster



830 Almond



173 Eggshell

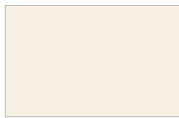

973 Antique White

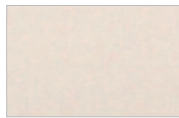

269 Chenille

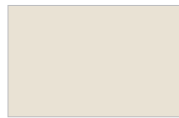

270 Linen



350 Vanilla

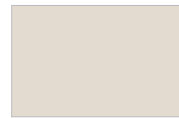

205 Fawn



186 Beige



064 Bronze

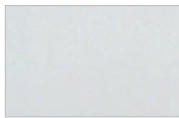

018 Satin Silver



748 Shadow Gray



190 Bright Aluminum



065 Brushed Aluminum

**HunterDouglas**   
Architectural

© Copyright Hunter Douglas Contract 2016

® Hunter Douglas and its product names are registered trademarks

® The GREENGUARD GOLD INDOOR AIR QUALITY CERTIFIED mark is a registered certification mark used under license through the GREENGUARD Environmental Institute.

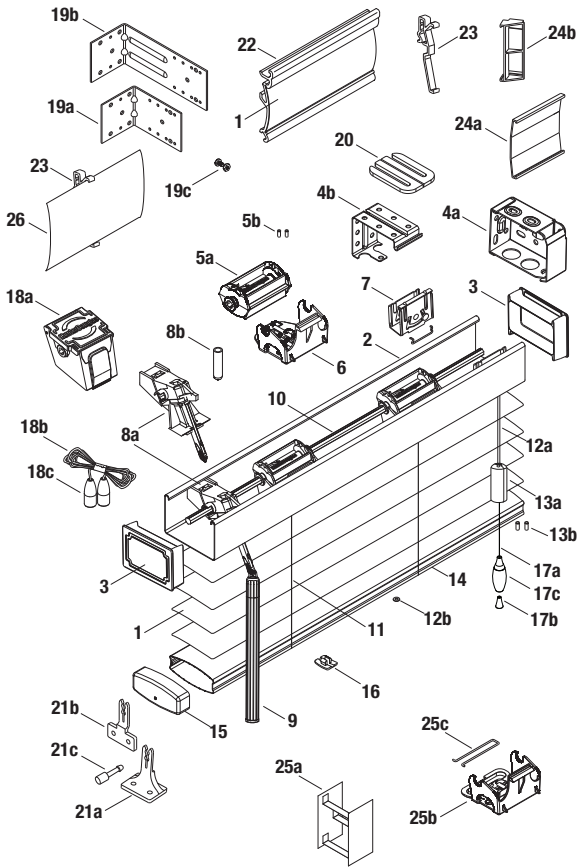

**STANDARD COMPONENTS:**

1. Slat
2. Headrail
3. Headrail End Cap
- 4a. Installation Bracket
- 4b. Intermediate Support Bracket
- 5a. Universal Tape Roll
- 5b. Cable Tape Grommet
6. Tape Roll Support – Ladder
7. Cordlock
- 8a. Wand Tilter
- 8b. Tilter Protector
9. Wand
10. Tiltrod
11. Cable Tape
- 12a. Lift Cord 1.4mm
- 12b. Lift Cord Grommet
- 13a. Cord Stop
- 13b. Safety Tassel Grommet
14. Bottom Rail
15. Bottom Rail End Cap
16. Tape Button
- 17a. Tassel Cord
- 17b. Conical Tassel Washer
- 17c. Tassel

**OPTIONAL COMPONENTS:**

- 18a. Cord Tilter
- 18b. Tilt Cord 1.4mm
- 18c. Tilter Tassels
- 19a. Short Extension Bracket
- 19b. Long Extension Bracket
- 19c. Extension Bracket Screw and Nut
20. Bracket Shim
- 21a. Hold-Down Bracket (Sill)
- 21b. Hold-Down Bracket (Jamb)
- 21c. Hold-Down Pin
22. Optional Valance
23. Valance Clip
- 24a. Valance Splice
- 24b. Valance Corner Clip
- 25a. Decorative Ladder Tape
- 25b. Tape Roll Support – Decorative Tape
- 25c. Decorative Tape Pin
26. Standard Valance

## PRODUCT SPECIFICATIONS

### PART 2 – PRODUCTS

#### 2.01 ACCEPTABLE MANUFACTURER

- A. Hunter Douglas Architectural / 13915 Danielson St., Ste.100/ Poway, CA 92064 / Phone: 800-727-8953 / Fax: 800-205-9819 / Website: HDarchitectural.com or architect approved equivalent.
- B. Product substitutions must be approved by architect minimum of 30 days prior to close of bid.

#### 2.02 2" HORIZONTAL ALUMINUM BLINDS

- A. **PRODUCT:** Hunter Douglas "H282 2" Aluminum Blind"

#### B. MATERIALS:

1. **SLATS:** 2" wide x .008" thick, heat-treated and spring tempered (except 5000 series alloy on metallized finishes) aluminum alloy 6011 with eased corners and manufacturing burrs removed. Product to have a minimum of 95% pre-consumer recycled content. Furnish not less than nominal 7.2 slats per foot routed on back edge (de-Light™ feature) to ensure superior closure and light control. Finish with manufacturer's standard baked-on finish in colors selected by architect from manufacturer's available contract colors utilizing Dust Shield™ finish to inhibit dust build-up for easier maintenance.
2. **SLAT SUPPORT:** Braided ladders of 100% polyester yarn color compatible with slats and spacing of ladder no more than 42mm.
3. **HEADRAIL:** U-shaped profile with rolled edges, measuring 1 1/2" x 2 1/4" x .024" constructed of corrosion resistant steel. Internally fit with components required for specified performance and designed for smooth, quiet, trouble-free operation. Headrail finish to be standard baked-on polyester and to match slats. Ends fitted with zinc coated steel end lock with adjustable tab for centering blinds.
4. **BOTTOM RAIL:** .019" steel, with corrosion-resistant finish formed with double-lock seam into closed oval shape for optimum beam and torsional strength. Ends fitted with color-coordinated engineered polymer caps. Color-coordinated engineered polymer tape buttons secure the ladder and cord. Bottom Rail finish to be standard baked-on polyester color coordinated to slats.

5. **LIFTING MECHANISM:** Crashproof steel cordlocks with corrosion-resistant finish and steel locking dogs, polyester cord which meet or exceed commercial specifications No/ 1029-86 lift cords, and Cord Stop/Single Pull Cord. Located on either side of individual blind unit as per architect's request.
6. **TILTING MECHANISM:** Die-cast helical worm and gear type tilter gear mechanism in polymer housing with clutch action to protect ladder tapes from over rotation of the solid steel, corrosion resistant tilt rod.
7. **TILT CONTROL WAND:** Tubular shaped 7/16" diameter extruded clear plastic, ribbed for positive grip and detachable without tools. Located on either side of individual blind unit as per architect's request.
8. **MOUNTING HARDWARE:** Manufacturer's standard .030" steel box brackets with baked-on polyester finish to match headrail with additional support brackets for blinds over 84" wide.
9. **ADDITIONAL AVAILABLE OPTIONS:** Cord Tilt, Valance, Hold Down Brackets, 2 or 3 Blinds on 1 Headrail, Cutouts.

#### 2.03 FABRICATION

- A. Blind measurements shall be accurate to within + 1/8" or as recommended in writing by manufacturer.

#### 2.04 FINISHES

- A. **SLAT** finish selection from the following: 002 Alabaster, 018 Satin Silver, 064 Bronze, 065 Brushed Aluminum, 110 Gloss White, 125 Bright White, 174 Eggshell, 186 Beige, 190 Bright Aluminum, 206 Fawn, 269 Chenille, 270 Linen, 350 Vanilla, 748 Shadow Gray, 830 Almond, 885 Flex White, 973 Antique White, 974 Pearl.
- B. **SLAT SUPPORT** braided ladders shall be color coordinated with slat