

# H2TN 2" Aluminum Horizontal Blinds



Offering maximum strength and sleek styling, our H2 blinds give the traditional look of 2" slats and can be optimized for a range of design applications. Model H2TN (School Blind) is optimized for the design and durability requirements of academic institutions, with sturdy vinyl tapes, 2.2mm cords, and cord tilt.

## KEY FEATURES

- 1 1/2" x 2 1/4" x .024" Headrail
- Heat-treated, spring-tempered aluminum slats
- Closed oval steel bottom rail provides optimal strength to prevent bowing
- Slats contain 95% recycled aluminum content and are GREENGUARD GOLD Indoor Air Quality Certified®
- Cord stop to single cord pull
- Ladder tapes in vinyl
- Lifetime Guarantee



## Slat Color Options



## Tape Color Options



**HunterDouglas**   
Architectural

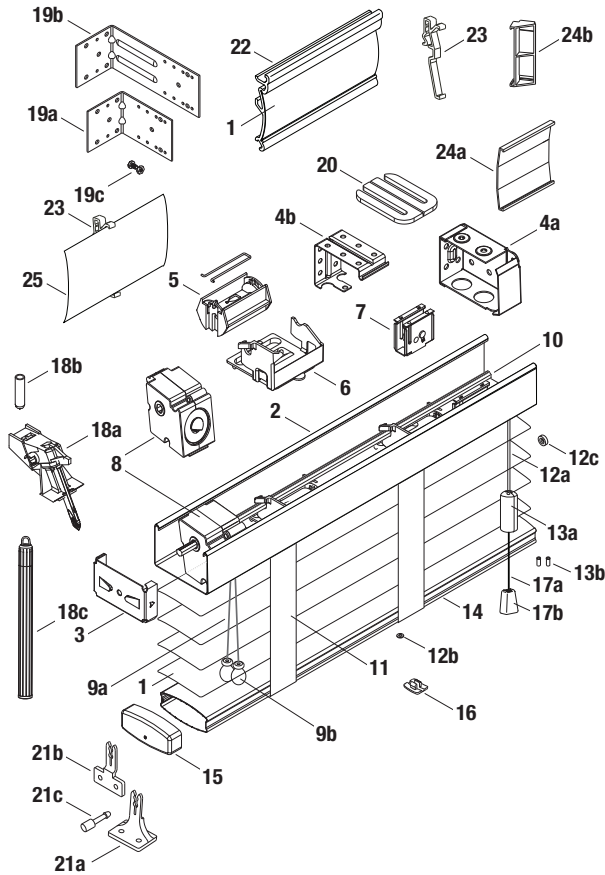

**STANDARD COMPONENTS:**

1. Slat
2. Headrail
3. Headrail End Lock
- 4a. Installation Bracket
- 4b. Intermediate Support Bracket
5. Tape Roll
6. Tape Roll Support
7. Cordlock
8. Cord Tilter
- 9a. Tilt Cord 2.2mm
- 9b. Tilter Tassels
10. Tilt Rod
11. Cable Tape
- 12a. Lift Cord 2.2mm
- 12b. Lift Cord Grommet
- 12c. Safety Cord Stop
- 13a. Cord Stop
- 13b. Safety Tassel Grommet
14. Bottom Rail
15. Bottom Rail End Cap
16. Tape Button
- 17a. Lift Cord
- 17b. Universal Cover/Tassel

**OPTIONAL COMPONENTS:**

- 18a. Wand Tilter
- 18b. Tilter Protector
- 18c. Wand
- 19a. Short Extension Bracket
- 19b. Long Extension Bracket
- 19c. Extension Bracket Screw and Nut
20. Bracket Shim
- 21a. Hold-Down Bracket (Sill)
- 21b. Hold-Down Bracket (Jamb)
- 21c. Hold-Down Pin
22. Optional Valance
23. Valance Clip
- 24a. Valance Splice
- 24b. Valance Corner Clip
25. Standard Valance

## PRODUCT SPECIFICATIONS

### PART 2 – PRODUCTS

#### 2.01 ACCEPTABLE MANUFACTURER

- A. Hunter Douglas Architectural / 13915 Danielson St., Ste.100/ Poway, CA 92064 / Phone: 800-727-8953 / Fax: 800-205-9819 / Website: HDarchitectural.com or architect approved equivalent.
- B. Product substitutions must be approved by architect minimum of 30 days prior to close of bid.

#### 2.02 2" MINI HORIZONTAL ALUMINUM BLINDS

- A. **PRODUCT:** Hunter Douglas "H2TN (School Blind) 2" Aluminum Blind"
- B. **MATERIALS:**

1. **SLATS:** 2" wide x .008" thick, heat-treated and spring tempered (except 5000 series alloy on metallized finishes) aluminum alloy 6011 with eased corners and manufacturing burrs removed. Product to have a minimum of 95% pre-consumer recycled content. Furnish not less than nominal 7.2 slats per foot to ensure tight closure and light control. Finish with manufacturer's standard baked-on finish in colors selected by architect from manufacturer's available contract colors utilizing Dust Shield™ finish to inhibit dust build-up for easier maintenance.
2. **SLAT SUPPORT:** Vinyl tapes constructed of one-piece vinyl with 1 1/2" wide twin or single-ladders and uniform spacing of 16 ladders to 26" of tape (42mm). Tapes and ladders exceed commercial specification No. 1029-86 and provide a maximum 34" distance between tapes.
3. **HEADRAIL:** U-shaped profile with rolled edges, measuring 1 1/2" x 2 1/4" x .024" constructed of corrosion resistant steel. Internally fit with components required for specified performance and designed for smooth, quiet, trouble-free operation. Headrail finish to be standard baked-on polyester and to match slats. Ends fitted with zinc coated steel end lock with adjustable tab for centering blinds.

4. **BOTTOM RAIL:** .019" steel, with corrosion-resistant finish formed with double-lock seam into closed oval shape for optimum beam and torsional strength. Ends fitted with color-coordinated engineered polymer caps. Color-coordinated engineered polymer tape buttons secure the ladder and cord. Bottom Rail finish to be standard baked-on polyester color coordinated to slats.
5. **LIFTING MECHANISM:** Crashproof steel cordlocks with corrosion-resistant finish, steel locking dogs, hexagon pulley, polyester 2.2mm lift cords, and Break-Thru® safety tassel. Located on either side of individual blind unit as per architect's request.
6. **TILTING MECHANISM:** Cord tilter consisting of zinc die-cast helical gear type driven by a worm in enclosed polymer housing, 2.2mm polyester cord, and solid steel corrosion resistant tilt rod.
7. **TILT CONTROL CORD:** 2.2mm polyester cord. Located on either side of individual blind unit as per architect's request.
8. **MOUNTING HARDWARE:** Manufacturer's standard .030" steel box brackets with baked-on polyester finish to match headrail with additional support brackets for blinds over 84" wide.
9. **ADDITIONAL AVAILABLE OPTIONS:** Wand Tilt, Valance, Hold Down Brackets, 2 or 3 Blinds on 1 Headrail, Cutouts.

#### 2.03 FABRICATION

- A. Blind measurements shall be accurate to within + 1/8" or as recommended in writing by manufacturer.

#### 2.04 FINISHES

- A. **SLAT** finish selection from the following: 002 Alabaster, 018 Satin Silver, 064 Bronze, 065 Brushed Aluminum, 110 Gloss White, 125 Bright White, 174 Eggshell, 186 Beige, 190 Bright Aluminum, 206 Fawn, 269 Chenille, 270 Linen, 350 Vanilla, 748 Shadow Gray, 830 Almond, 885 Flex White, 973 Antique White, 974 Pearl.
- B. **SLAT SUPPORT** braided ladders shall be color coordinated with slat.