

**Techstyle**<sup>®</sup>  
ACOUSTICAL CEILINGS

**HunterDouglasContract**

CEILINGS

**Innovative products  
make innovative projects.**





For 80 years, Hunter Douglas Contract has worked with the architecture and design community to set new standards in product design and performance. Continuing this tradition of excellence, Techstyle® Acoustical Ceilings bring unprecedented acoustical performance, aesthetics and accessibility to the industry.

Project: Lida Baday Showroom, New York, NY  
Architect: Mario Zuliani + Associates  
Panel: 4'x 4' white

ILLUMINATION 2

ACCESS 4

TRIM 6

DESIGN FLEXIBILITY 8

ACOUSTICS 10

HVAC/LIGHTING 12

TRADITIONAL SERIES 14

PRODUCT SPECS 15

# Designing with light.

Techstyle® Acoustical Ceilings are designed to maximize the impact of light. The highly reflective smooth textile surface can move daylight into a space or host the projection of exotic colors. Unique combination of panel materials can also create a luminescent glow distinctly defined by the type of fixture, the spacing, and the color of bulbs.

Project: Clayco Headquarters, St. Louis, MO  
Architect: Clayco/Forum Studio, Inc.  
Panel: 4'x 4' white





Project: Deloitte Headquarters, Copenhagen, NL  
Architect: 3XN, Aarhus, DK  
Product: 1200x1200 white



Project: Cisco Systems EBC, San Jose, CA  
Interior Design: HOK  
Panel: 4'x 4' white

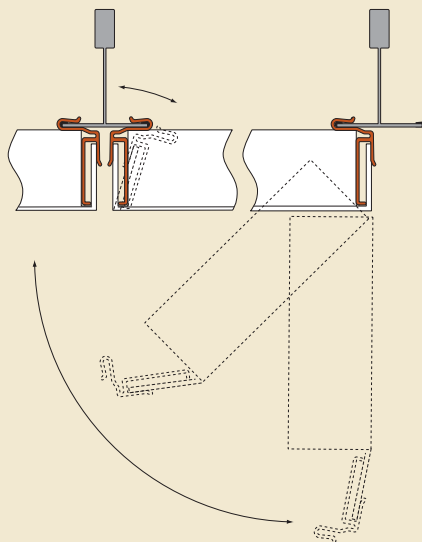

### ACCESS

For access, simply apply pressure to either hinge side and the panel will swing down, allowing total access to the plenum.

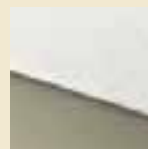
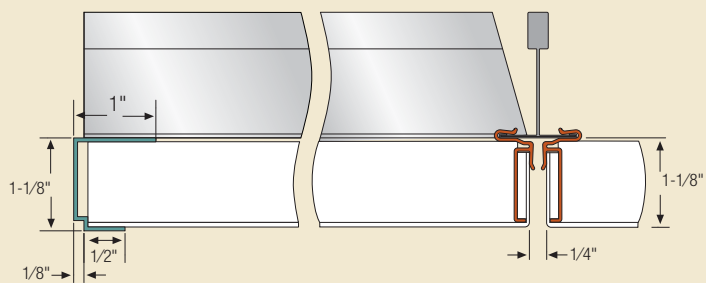

### PERIMETER OPTION #1

Using the Reveal Edge Wall Channel (WT1) creates a 1/8" reveal from the wall to the panel. This channel may be curved to a concave or convex radius of 36".

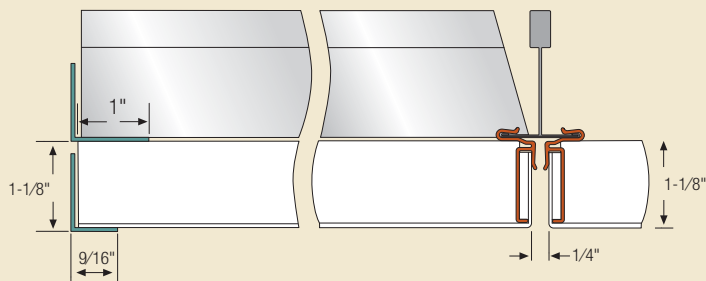

### PERIMETER OPTION #2

Two wall angles may also be used for a more traditional appearance.



Techstyle® ceilings offer the easiest access in the industry. Our integrated clip/hinge system leaves panels clean and untouched, allowing them to swing safely away during access. Press gently just inside the reveal and the panel disengages and swings down, allowing total access to the plenum while holding tiles securely in place.

ACCESS

## Goodbye to ‘lift and shift.’

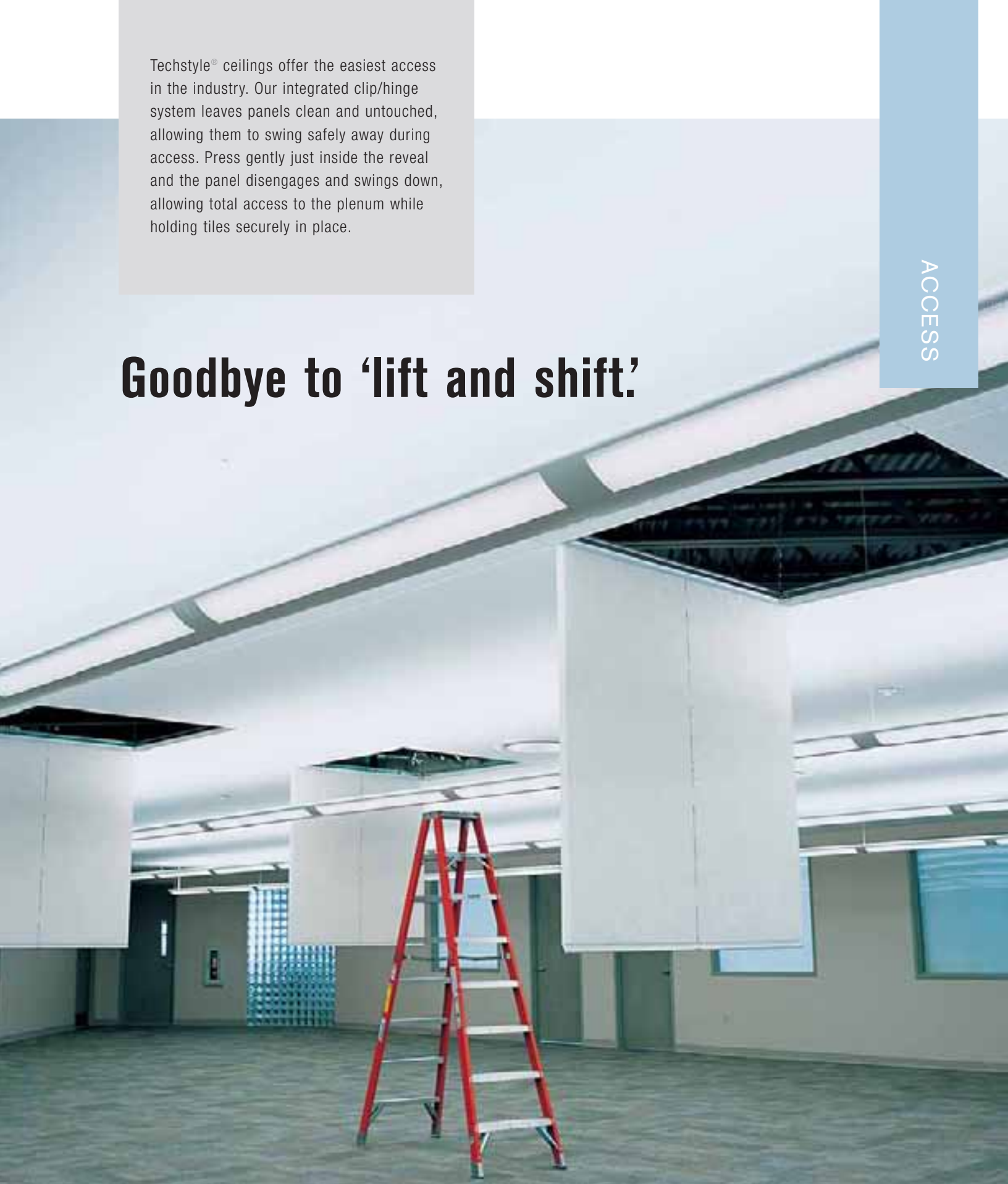

## The perfect fit.

Techstyle® Acoustical Ceilings self-aligning panels provide a consistently narrow 1/4" reveal, which ensures uniformity throughout a space. Panels line up as they should, creating a clean, monolithic look.

Proper ceiling alignment: It's just one more thing we worry about so you don't have to.

Project: John and Mary Pappajohn Higher Education Center,  
Des Moines, IA  
Architect: Herbert Lewis Kruse Blunck Architecture  
Panel: 4'x 4' white



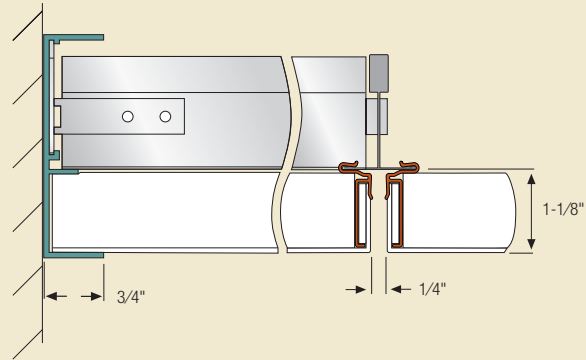

**CURVED WALL**

Curved wall transitional trim from drywall to suspended ceilings.

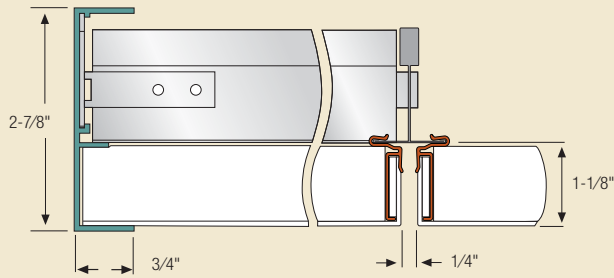

**FLOATING PERIMETER #1**

Trim to create a "floating" ceiling using the Floating Perimeter Trim (TF2, shown in photo on page 8). This trim may be curved to a concave or convex radius of 24".

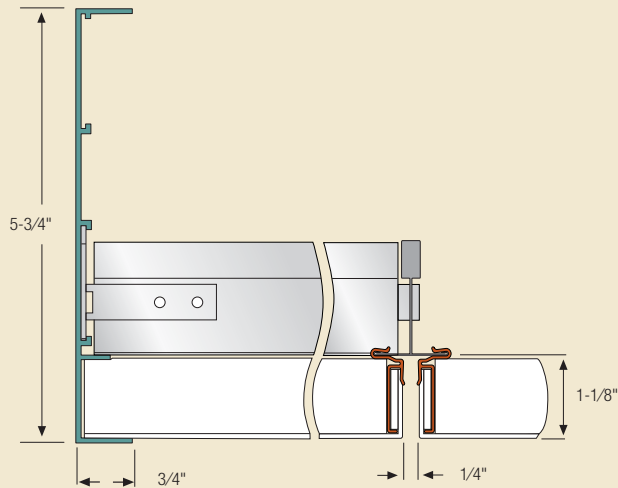

**FLOATING PERIMETER #2**

Trim to create a "floating" ceiling using the Floating Perimeter Trim (TF5). This trim may be curved to a concave or convex radius of 40".

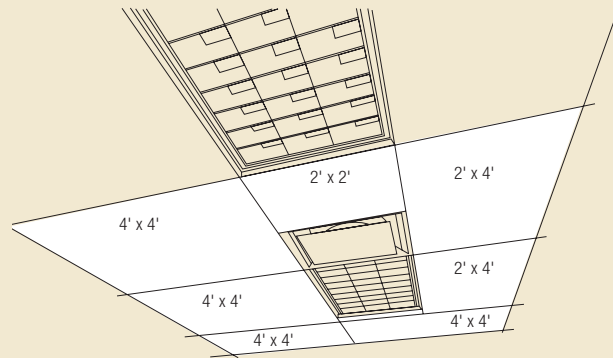
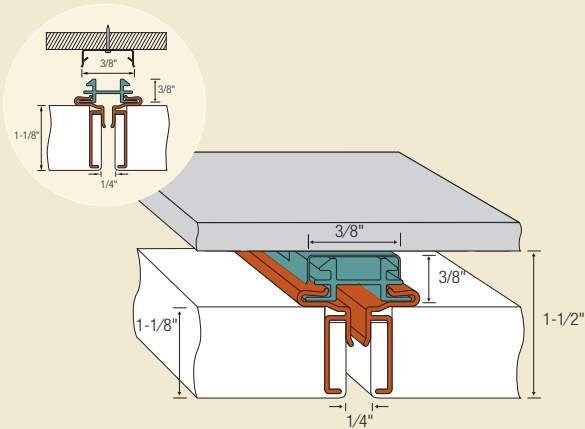

### DIRECT MOUNT

Techstyle Acoustical Ceilings may be direct or surface-mounted to a hard surface (ceiling or wall) to add acoustics to a space. The narrow reveal is maintained in one or both directions by snapping the panels into the A-mount Rail (AM1). The overall depth of the system is 1.5 inches.

### COLOR PALETTE

Exercise your creativity by combining various colors and sizes of Techstyle Acoustical Ceilings. Above, 4' x 4' panels in white and black are combined to create an interesting checkerboard effect.

### PANEL SIZE

Panels come in standard sizes from 2' x 2' to 4' x 6' and may be combined to more precisely fit a space.

## Go ahead, create.

Techstyle® ceilings bring design flexibility to the forefront with panels that come standard in sizes ranging from 2' x 2' to 4' x 6'. Our modular system lets you mix and match sizes to create distinct looks for a room.

Whether your project uses a T-grid or calls for a direct mount, tiles are easy to field-adjust to fit nearly any application. From islands to curves along a wall, Techstyle Acoustical Ceilings have got you covered.

Project: Denver Art Museum, Frederic C. Hamilton Building,  
Denver, CO  
Architect: Studio Daniel Libeskind, Davis Partnership Architects  
Panel: 2' x 5' off white

# Bringing innovation to new heights.

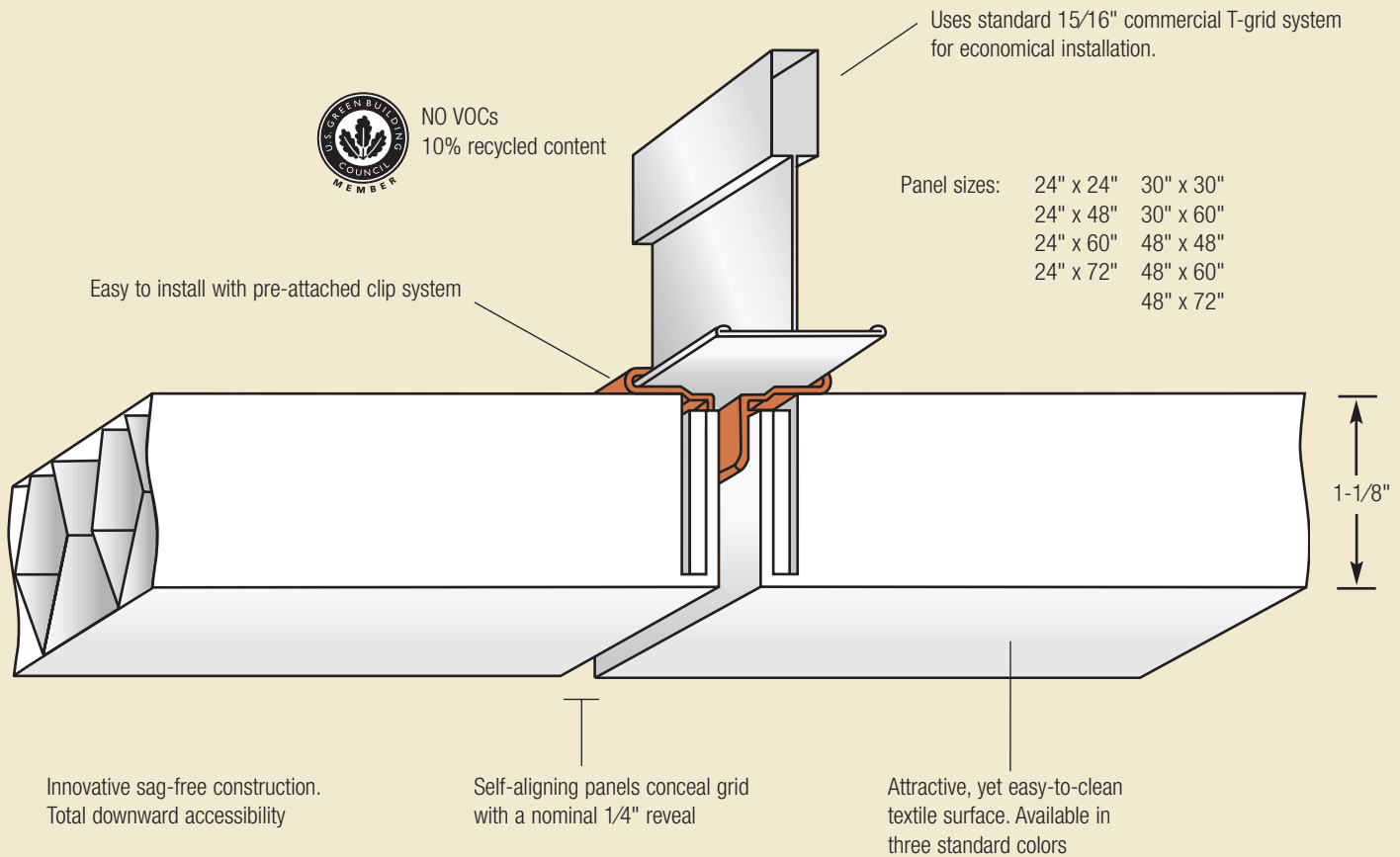

Bridging the gap between function and form, Techstyle® panels represent a new way of looking at ceilings. The cellular construction provides exceptional acoustical performance in a variety of sizes. Panels that come standard in white, off-white and black offer a multitude of design possibilities.

**Techstyle**®  
ACOUSTICAL CEILINGS



### COMPARATIVE NOISE REDUCTION COEFFICIENT (NRC)

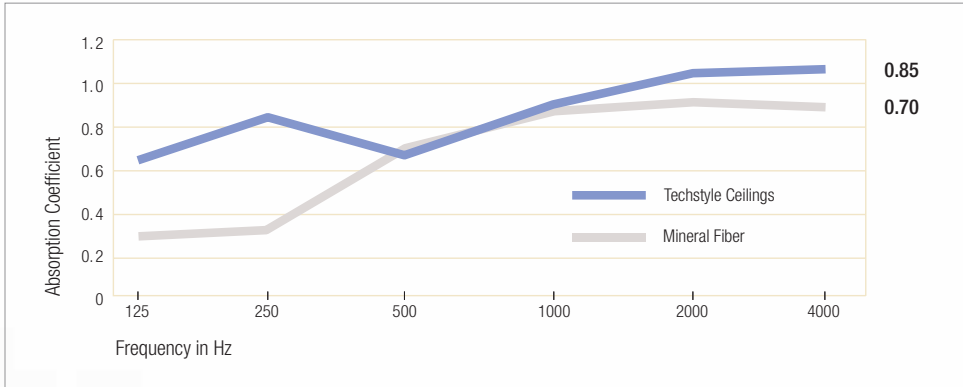

# An air of sophistication.



## SQUARE DIFFUSER

The square diffuser shown is Titus Omni Diffuser (2' x 2') Border T.

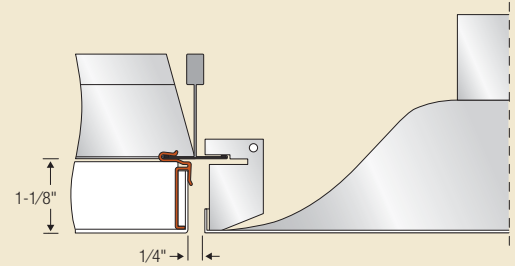

## CIRCULAR DIFFUSER

A circular diffuser in the center of 4' x 4' panel. Diffuser shown is the Titus R-Omni Diffuser.

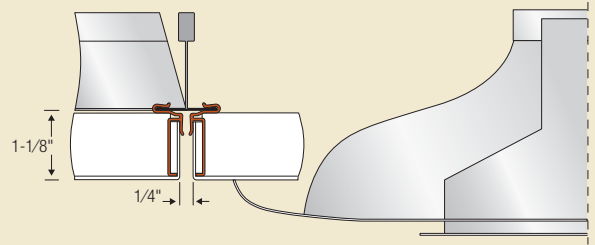

## AIR BAR

As shown at right, Techstyle ceilings can easily accommodate air bars. Flow bar shown is Titus type 77.

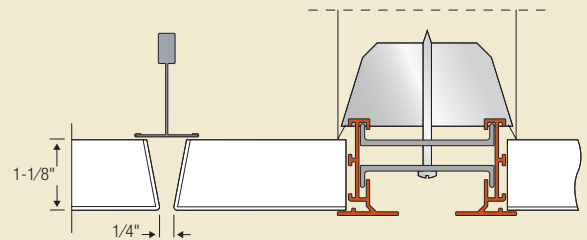

# A bright idea.

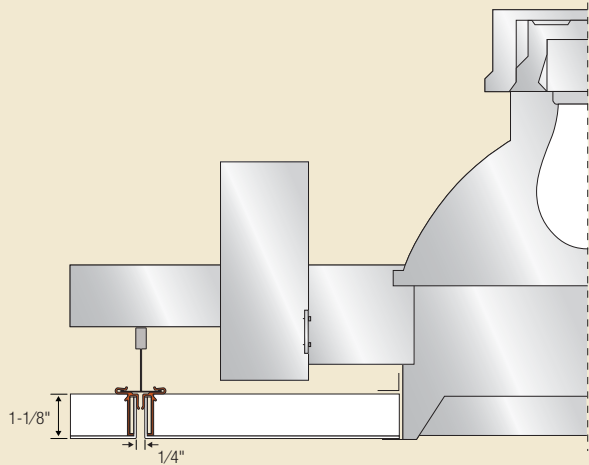

## CAN LIGHTING

Common can or down lights integrate easily with Techstyle Acoustical Ceilings.

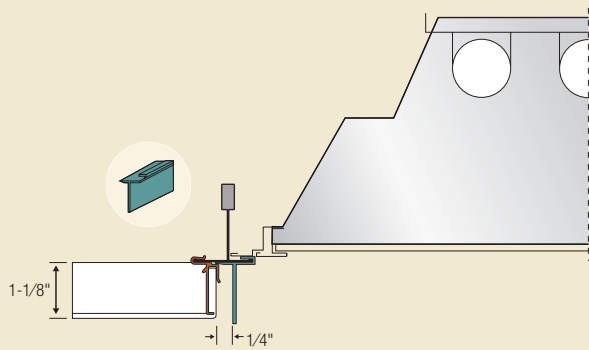

## TYPE-G FLUORESCENT

The Reveal Light Trim (LT) creates a subtle reveal between the recessed (Type-G fluorescent) fixture and the Techstyle panel. This trim is available in modular kits to fit most common fixture sizes.

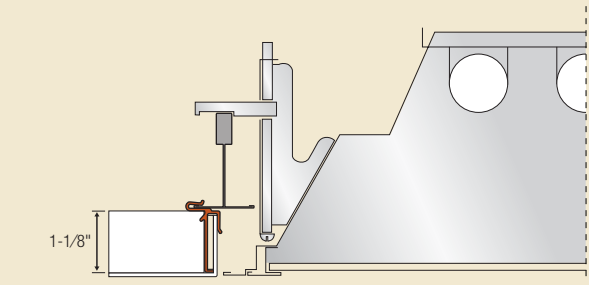

## TYPE-M FLUORESCENT

Type-M fluorescent light fixtures may be suspended level with the surface of the panels.

# Old grid. New ceiling.



Techstyle® Traditional Series tiles offer the same innovative panel as a lay-in for a more traditional appearance. Traditional Series tiles work with your existing grid and accommodate all standard features without sacrificing options, acoustical performance or flexibility.

## TRADITIONAL SERIES

## Available Sizes

Panel Sizes	Flat, Commercial T-Grid	
	15/16"	9/16"
24" x 24"	■	■
24" x 48"	■	■
24" x 60"	■	■
24" x 72"	■	■
24" x 96"	■	N/A
30" x 30"	■	■
30" x 60"	■	■
30" x 72"	■	■
48" x 48"	■	■
48" x 60"	■	■
48" x 72"	■	■

Metric sizes are available, please consult factory.



### TECHSTYLE CEILINGS' ENVIRONMENTAL BENEFITS

No VOC's (Volatile Organic Compounds), preserves IAQ (indoor air quality)

10% recycled content

Durable panels ensure long product lifespan and maximize sustainability

Lightweight product (0.30 lb/sf) means less landfill waste at end of product life

100% Recyclable



PRODUCT SPECIFICATIONS

CLASSIC SERIES

<b>Substrate</b>	Acoustical mat		
<b>Color</b>	White, Off-white and Black		
<b>Surface Finish</b>	Polyester Non-woven		
<b>Panel Sizes</b>	<b>Thickness</b>	1-1/8"	
	<b>Sizes</b>	24" x 24"	30" x 30"
		24" x 48"	30" x 60"
		24" x 60"	48" x 48"
		24" x 72"	48" x 60"
			48" x 72"
	Metric sizes are available, please consult factory.		
<b>Acoustical Ratings</b>	<b>NRC</b>	0.85 (ASTM C 423)	
	<b>CAC</b>	17 w/no backer, (ASTM E 1414)	
<b>Light Reflectance</b> <i>(white only)</i>	LR-1 (77%) (ASTM E 1477)		
<b>Surface Burning</b>		Class A(1) (ASTM E 84) (ASTM E 1264)	
	<b>Flame</b>	<25	
	<b>Smoke</b>	<50	
<b>Moisture Resistance</b>	Resistant to 95% humidity in 104° F temperature		
<b>Thermal Resistance</b>	N/A		
<b>Fungal Resistance</b>	Resistant (ASTM C 1338)		
<b>Weight of Panel</b>	0.30 pounds per square foot		
<b>Warranty</b>	10 year limited		
<b>MEA</b>	Acceptance (376-02-M)		
<b>ICC</b>	Approval (ER-6138)		
<b>CHPS</b>	Passed		

\*Test results available upon request

*Large Photo, Right:*

Everett Events Center, Everett, WA  
Architect: H2K Design and Botesch, Nash & Hall  
Panel: Techstyle 4' x 4' white



*Above, Left to Right:*

BART Station, San Francisco, CA  
Architect: ED2 International  
Product: Metal linear ceilings

Greenview School, Greensboro, NC  
Architect: Calloway, Johnson, Moore & West  
Product: Metal linear with white oak veneer

Museum of Photographic Arts, San Diego, CA  
Architect: David Raphael Singer  
Product: Metal curved plank ceilings

Reebok Headquarters, Canton, MA  
Architect: NBBJ of Seattle  
Product: Metal plank and tile ceilings

Ft. Lauderdale Airport, Ft. Lauderdale, FL  
Architect: HOK  
Product: Metal screen/baffle

Bondi Icebergs Club, Sydney, Australia  
Architect: Lazzarini & Pickering Architects  
Product: Metal acoustical ceiling panels

*Cover:* Cisco Systems EBC, San Jose, CA  
Interior Design: HOK  
Panel: 4' x 4' white





As architects and designers have expanded the boundaries of design, Hunter Douglas Contract has been there, working alongside them. Our acoustical and metal ceilings systems can be found in some of the world's most recognizable projects. The industry keeps changing, but our principles stay the same.

We've based our products on the idea that to do their finest work, architects and designers need the finest materials.

*Innovative products make innovative projects.*

## Learn More

- Call 866.556.1235 to speak with a specialist
- Visit [www.hunterdouglascontract.com/ceilings](http://www.hunterdouglascontract.com/ceilings)
- Sign up for *Profiles*, our international email bulletin

# HunterDouglasContract

WINDOW COVERINGS

CEILING

SOLAR CONTROL



Hunter Douglas Contract  
One Hunter Douglas Circle  
Thornton, CO 80241  
phone: 866.556.1235  
fax: 720.872.7850  
[www.hunterdouglascontract.com/ceilings](http://www.hunterdouglascontract.com/ceilings)