

EXTERIOR SOFFITS

EXTERIOR EXTERIOR PLANK



When heavier-duty, non-accessible metal soffits are required, Exterior Planks can provide solutions.

Project: St. Luke's Professional Building, Houston, TX; Exterior Plank

KEY FEATURES

- Panel sizes:
  - 6" to 24" widths up to 120" long
- Square-edge design
- Waste reduction with factory fabricated dimensional material
- Downweight: reduce dead load with lightweight aluminum
- Non-accessible

TYPICAL ISOMETRICS

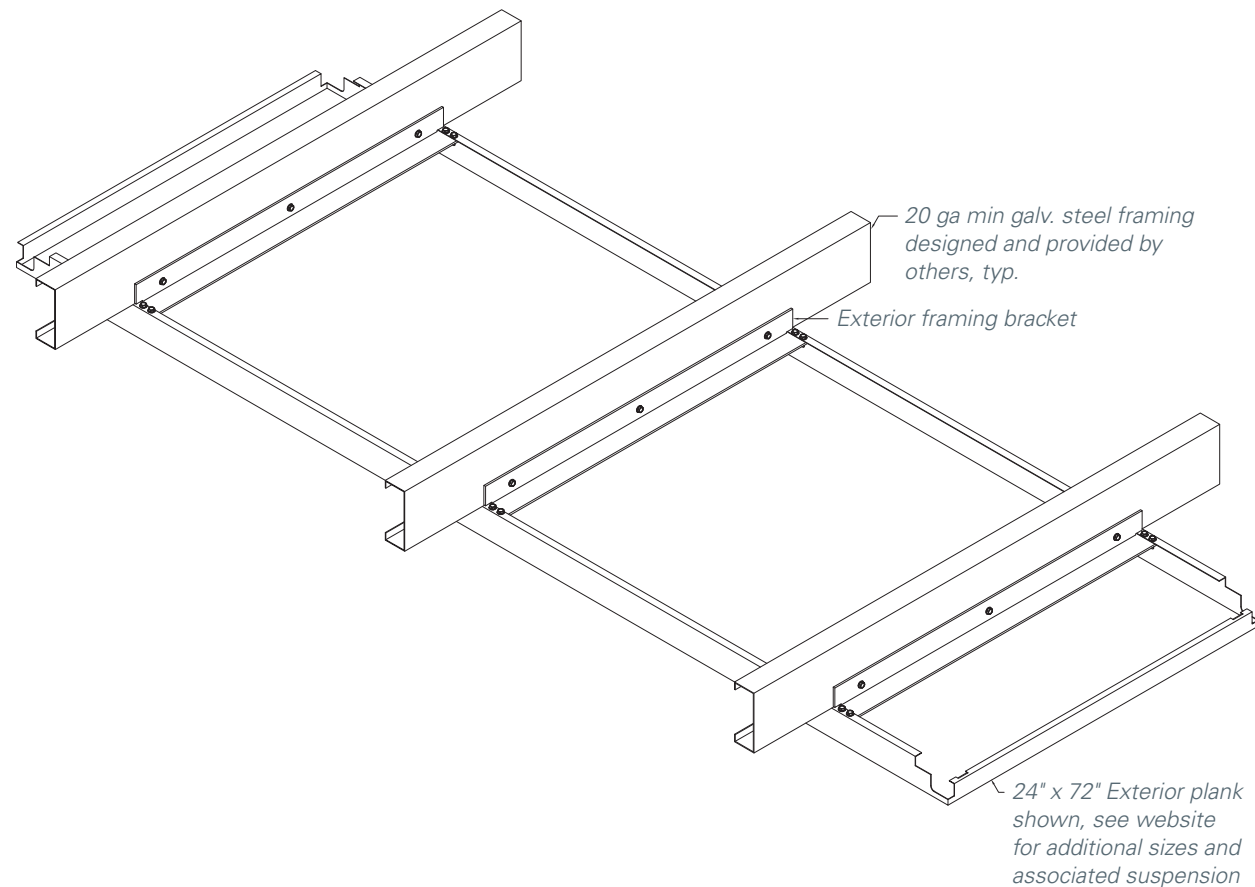

PHYSICAL DATA

Substrate: Aluminum  
 Warranty: 1 year  
 Seismic rating: Zones A,B,C,D,E,F  
 Fire rating: Class A Fire Rated per ASTM E84  
 – Painted or anodized metal: Flame spread: ≤ 25, Smoke ≤ 50  
 Weight: Varies  
 Wind load: Per code  
 Recycled content: Up to 85%

BIM

REVIT files available for BIM contributions, see website for details.

LEED V4 CREDITS

EA: Optimize Energy Performance  
 MR: Building Product Disclosure  
 EQ: Low-Emitting Materials  
 EQ: Indoor Air Quality Assessment

CERTIFICATIONS

GREENGUARD Gold Certified  
 HPDs & EPDs – available upon request

EXTERIOR SOFFITS

EXTERIOR EXTERIOR PLANK

COLORS & FINISHES

Hunter Douglas offers a wide choice of colors and finishes. Some colors and finishes carry a premium price over manufacturer's standard colors. Custom color matching is available upon request. Please contact Hunter Douglas at 800-366-4327 for minimum quantities and lead times. To request samples, contact us at ceiling.samples@hunterdouglas.com. See website for the most up to date information. Colors are for illustration purposes only.

STANDARD PAINT COLORS



Natural 7163



Cotton White 0280

CUSTOM COLORS

Premium custom colors.



Custom

DECORATED WOOD-LOOK OPTIONS

Powder-coat paint finish (interior and exterior). Formaldehyde-free, Class A composite panel. This finish is recommended for exterior conditions.

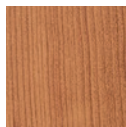

Fonthill Cherry 8422

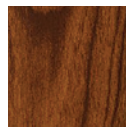

Walnut 8424

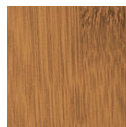

Amber Bamboo 8432

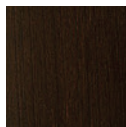

Fine Wenge 8433

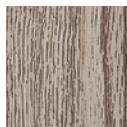

Grey Barnwood Cedar 8434

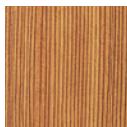

Golden Douglas Fir 8436



American Oak 8439



Cajun Cypress 8442

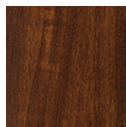

Swamp Cypress 8444



Clipper Teak 8446



Windjammer Teak 8449



Douglas Fir 8452



Anigre 8453



Farm Maple 8458



Caravel Teak 8460

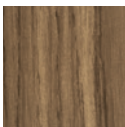

Regatta Teak 8461



Summer Maple 8465



Terrace Maple 8466



Red River Pecan 8467

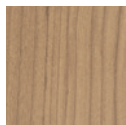

Bayou Pecan 8468



Northwest Mountain Hemlock 8486



Whitewash 8487

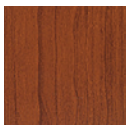

Rustic Cherry 8739

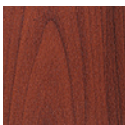

Cherry 8742



Project: St. Luke's Professional Building, Houston, TX; Exterior Plank