

METAL CEILINGS

PLANK & TILE  
SNAP-IN

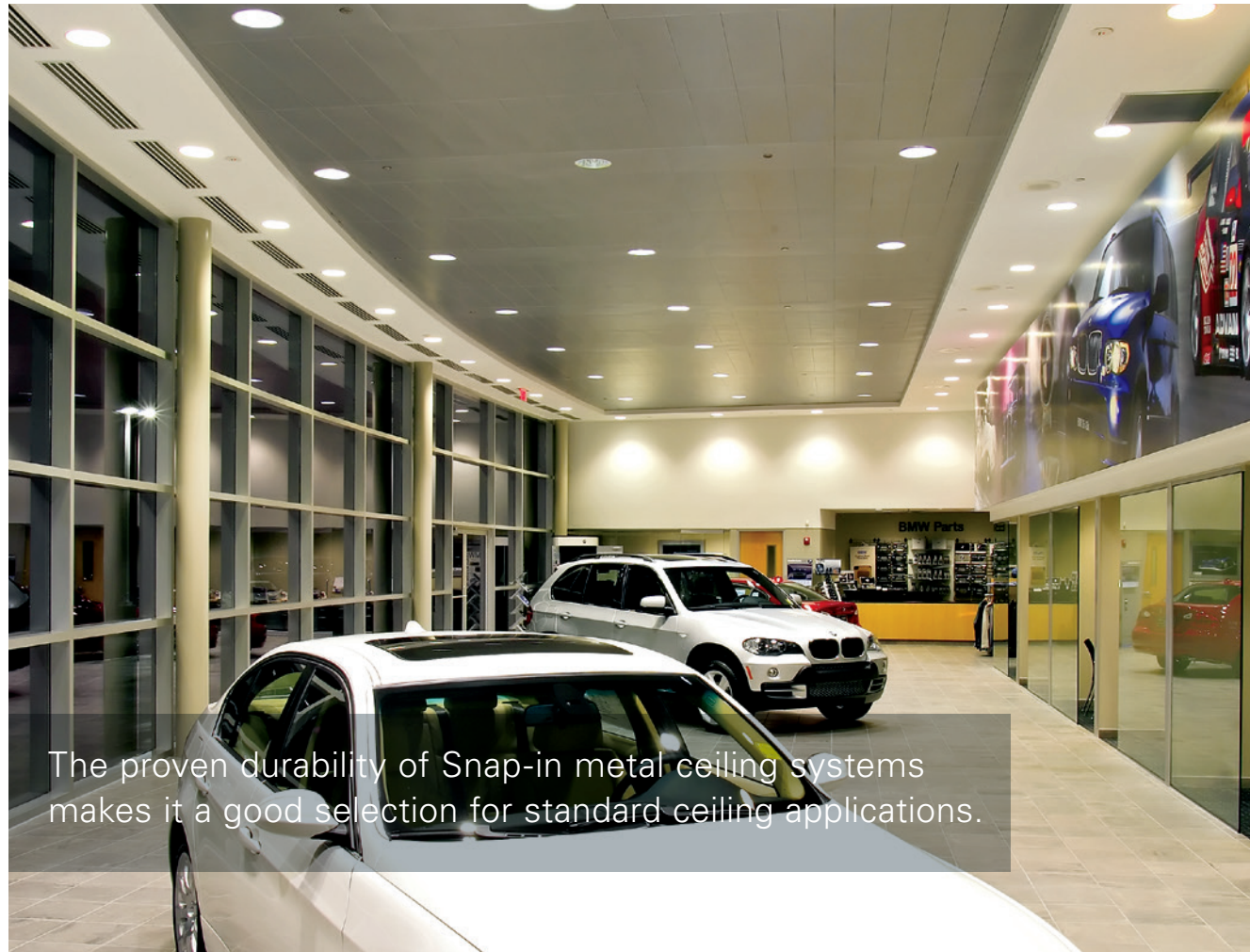

The proven durability of Snap-in metal ceiling systems makes it a good selection for standard ceiling applications.

Project: Auto Showroom, Chattanooga, TN; Snap-In

KEY FEATURES

- Three panel size sets:
  - 12" up to 96"
  - 24" x 24"
  - 24" x 48"
- Square-edge design
- Waste reduction with factory fabricated dimensional material
- Downweight: reduce dead load with lightweight aluminum
- Interior and exterior applications
- Compatible with industry standard lighting, HVAC, speaker, fire safety, and security services

TYPICAL ISOMETRICS

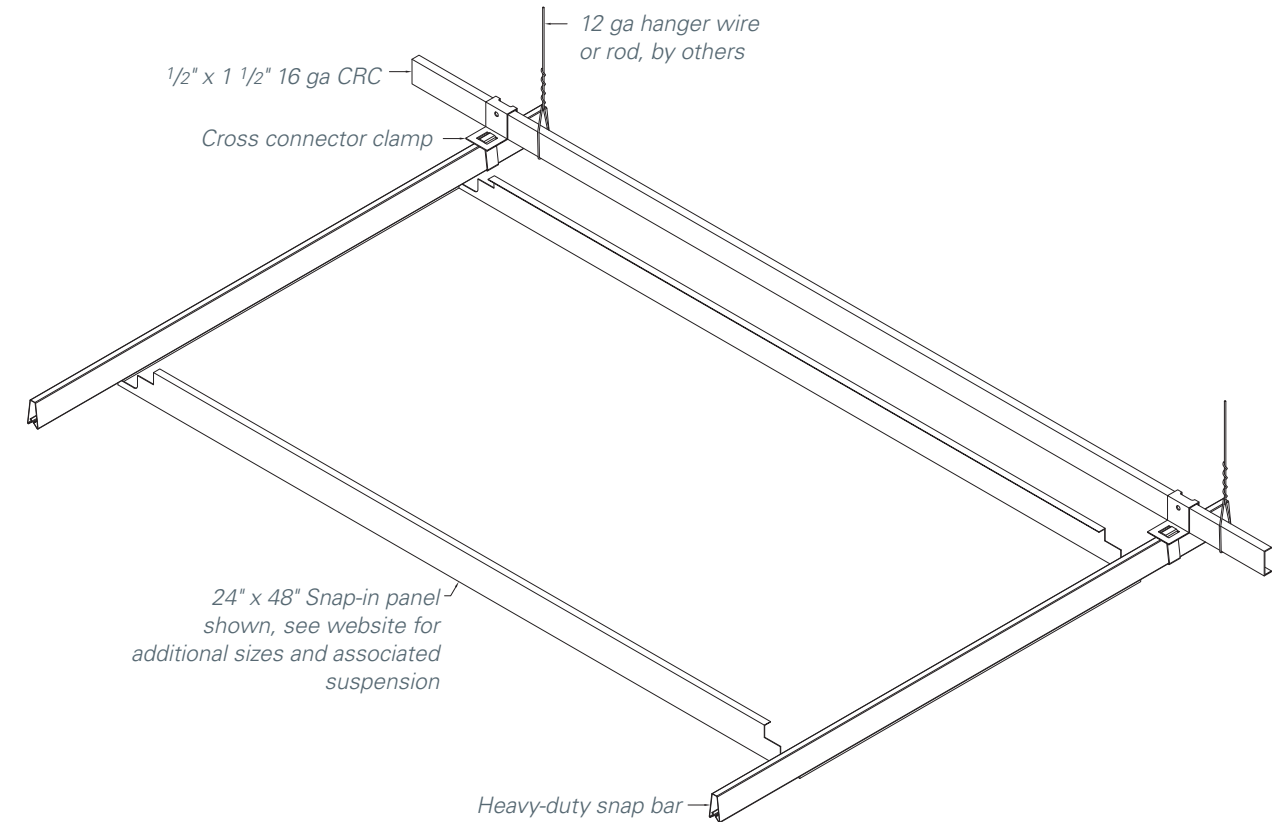

PERFORATION PATTERNS

Standard patterns shown. See page 238 to see all perforation patterns. Scale shown: 1:1, unless otherwise noted.

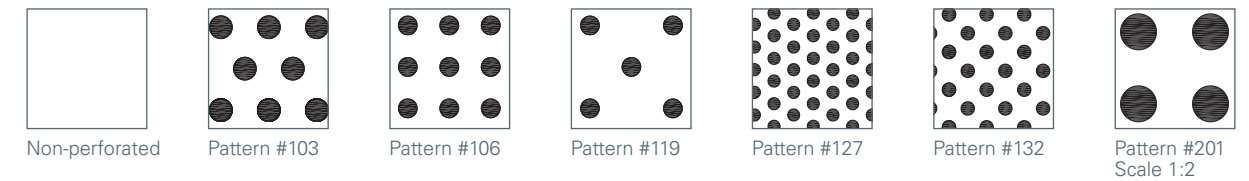

PHYSICAL DATA

**Substrate:** Aluminum  
**Warranty:** 1 year  
**Seismic rating:** Zones A,B,C,D,E,F  
**Fire rating:** Class A Fire Rated per ASTM E84  
 – Painted or anodized metal: Flame spread: ≤ 25, Smoke ≤ 50  
**Weight:** Varies 0.75 – 1.0 lbs./sq.ft.  
**Wind load:** N/A  
**Recycled content:** Up to 85%  
**Light reflectance (LR) Coefficient per ASTM E1264 & ASTM E1477:**  
 – Varies with finish  
 – Cotton White: LR = 0.81  
**Acoustical ratings – NRC:** See page 240

BIM

REVIT files available for BIM contributions, see website for details.

LEED V4 CREDITS

EA: Optimize Energy Performance  
 MR: Building Product Disclosure  
 EQ: Low-Emitting Materials  
 EQ: Indoor Air Quality Assessment  
 EQ: Daylight  
 EQ: Acoustic Performance

CERTIFICATIONS

GREENGUARD Gold Certified  
 HPDs & EPDs – available upon request

**METAL CEILINGS**

**PLANK & TILE SNAP-IN**

**COLORS & FINISHES**

Hunter Douglas offers a wide choice of colors and finishes. Some colors and finishes carry a premium price over manufacturer's standard colors. Custom color matching is available upon request. Please contact Hunter Douglas at 800-366-4327 for minimum quantities and lead times. To request samples, contact us at ceiling.samples@hunterdouglas.com. See website for the most up to date information. Colors are for illustration purposes only.

**STANDARD PAINT COLORS**



Natural 7163



Cotton White 0280

**WHITE FINISH OPTIONS**

Powder-coat paint finish for Arctic White #1015P (Gloss 10-20); Crystalline White #1050P (Gloss 45-55); Supernova White #1085P (Gloss 80-90)

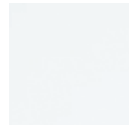

Arctic White 1015P



Crystalline White 1050P



Supernova White 1085P

**CUSTOM COLORS**

Premium custom colors.



Custom

**PERFORMANCE WHITE PAINT FINISH**

Powder-coat paint finish offering LRV 96; non-glare, 3% low gloss finish. Certified by: Applied Technical Services, Inc. Test Report No. D233185. Test reports available by request.



Performance White 9603P

**BLACK FINISH OPTIONS**

Powder-coat paint finish for Starless Black #5000P (Matte); Raven Black #5030P (Gloss 25-35); Sable Black #5060P (Gloss 65-75); Wet Glass Black #5095P (Gloss 90-95)



Starless Black 5000P



Raven Black 5030P



Sable Black 5060P



Wet Glass Black 5095P

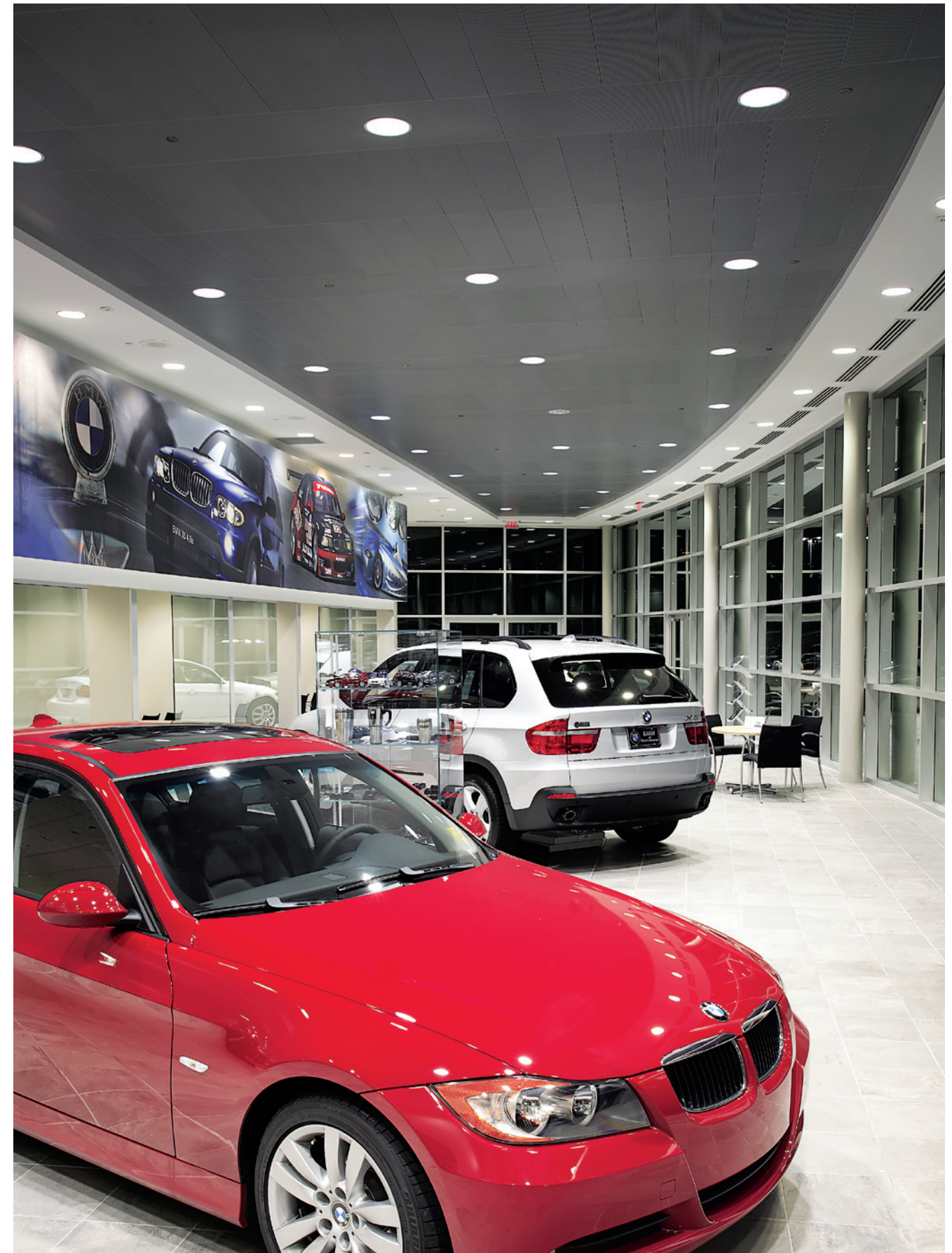

Project: Auto Showroom, Chattanooga, TN; Snap-In