

First Edition™ Alternative Wood Blinds



First Edition Alternative Wood Blinds are constructed with durable PVC and meet the requirements of the NFPA 701 Flame-Resistance test. First Edition blinds are perfect for high-moisture environments.

KEY FEATURES

- GREENGUARD Indoor Air Quality Certified® and GREENGUARD Children and Schools™ certified for low-emitting products
- EPIC™ hardware system for smooth operation
- Anti-static treatment reduces dust build-up
- Easy to clean – perfect for high-traffic areas
- Hunter Douglas Lifetime Guarantee

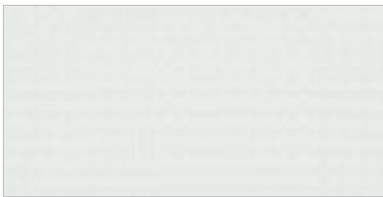

744 Marble Tile

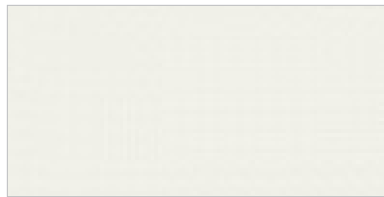

745 Sundrenched Cotton

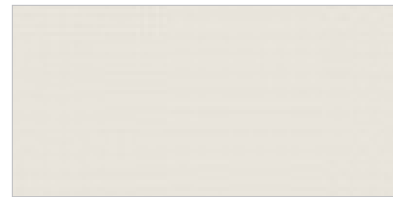

746 Canvas Tote

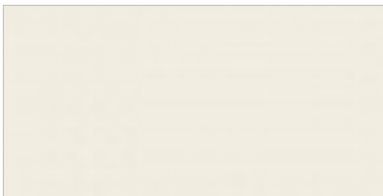

747 Lemon Verbena

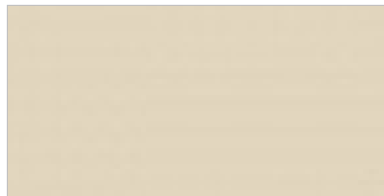

749 Vintage Linen

HunterDouglas 
Architectural

© Copyright Hunter Douglas Contract 2016

® Hunter Douglas and its product names are registered trademarks

® The GREENGUARD INDOOR AIR QUALITY CERTIFIED mark is a registered certification mark used under license through the GREENGUARD Environmental Institute.

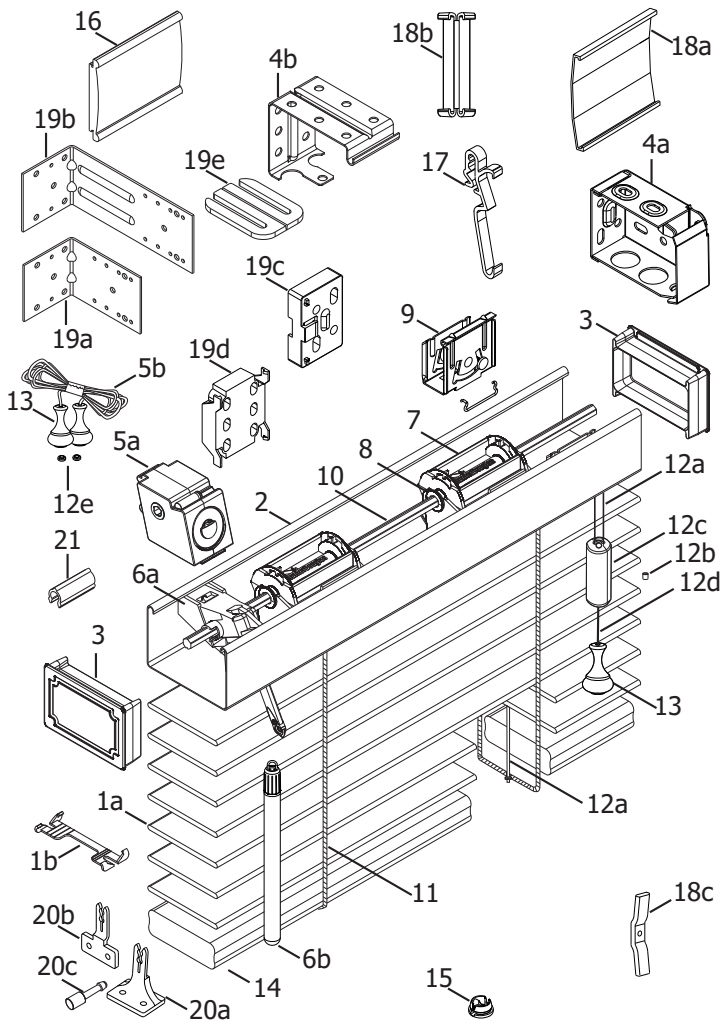

STANDARD PARTS

- 1a. Slat
- 1b. Tape Spacer
2. Headrail
3. Headrail End Cap
- 4a. Installation Bracket
- 4b. Intermediate Support Bracket
- 5a. Cord Tilter
- 5b. Tilt Cord 1.4mm
- 6a. Wand Tilter
- 6b. Tilter Protector
- 6c. Wand
7. Tape Roll 2" Unv. Epic™
8. Support Tape Roll (Ladders)
9. Cordlock
10. Tiltrod
11. No Loop Cable Tape
- 12a. Lift Cord 1.4mm
- 12b. Cord Stop Washer
- 12c. Cord Stop
- 12d. Tassel Cord 2.2mm
- 12e. Lift Cord Grommet
13. Wood Tassel
14. Bottom Rail
15. Tape Button
16. Valance
17. Universal Valance Clip
- 18a. Valance Splice
- 18b. Universal Valance Corner Key
- 18c. Child Safety Kit (Cord Cleat)

OPTIONAL PARTS

- 19a. Short Extension Bracket
- 19b. Long Extension Bracket
- 19c. Spacer Block (Bracket)
- 19d. Spacer Block (Support Bracket)
- 19e. Bracket Shim
- 20a. Hold-Down Bracket (Sill)
- 20b. Hold-Down Bracket (Jamb)
- 20c. Hold-Down Pin
21. Clip

PRODUCT SPECIFICATIONS

PART 2 – PRODUCTS

2.01 ACCEPTABLE MANUFACTURER

A. Hunter Douglas Architectural / 13915 Danielson St., Ste.100/Poway, CA 92064 / Phone: 800-727-8953 / Fax: 800-205-9819 / Website: HDarchitectural.com or architect approved equivalent.

B. Product substitutions must be approved by architect minimum of 30 days prior to close of bid.

2.01 2" HORIZONTAL FAUX WOOD BLINDS

A. PRODUCT: Hunter Douglas "First Edition™ 2" Horizontal FR Alternative Wood Blind"

B. MATERIALS:

- 1. SLATS:** 2" wide x 0.105" thick durable PVC. Furnish not less than nominal 7.2 slats per foot to ensure tight closure and light control. Finish with manufacturer's standard colors selected by architect from manufacturer's available contract colors.
- 2. SLAT SUPPORT:** Braided ladders of 100% polyester yarn color compatible with slats and spacing of ladder no more than 11".
- 3. HEADRAIL:** U-shaped profile with rolled edges, measuring 1 1/2" x 2 1/4" x .024" constructed of corrosion resistant steel and providing a sleek low profile design. Internally fit with components required for specified performance and designed for smooth, quiet, trouble-free operation. Headrail finish to be standard baked-on polyester and to coordinate with slats. End caps fitted on headrail for a clean product appearance.
- 4. BOTTOM RAIL:** 1.95" wide x 0.64" thick PVC rectangular in shape. Color-coordinated engineered polymer tape buttons secure the ladder and cord. Finish to be manufacturers standard colors or stained finish to match slats.

5. LIFTING MECHANISM: Engineering polymer and galvanized steel housing cordlocks with polymer roller bearing and steel locking pin system, two-ply polyester cord filler in braided polyester jacket lift cords meet or exceed commercial specification 1029.86, and fracture-resistant polymer cord-stop color-coordinated to slat. Located on either side of individual blind unit as per architect's request.

6. TILTING MECHANISM: Permanently lubricated and fully enclosed standard cord tilt holds and tilts slats at any angle. Optional wand tilt of worm and gear construction incorporated into tilter mechanism. Solid steel, corrosion resistant tilt rod.

7. TILT CONTROL WAND: Rounded 3/8" diameter constructed of quality selected hardwood stained and lacquered or painted to match slats and detachable without tools. Located on either side of individual blind unit as per architect's request.

8. MOUNTING HARDWARE: Manufacturer's standard .030" galvanized steel box brackets with baked-on polyester finish to match headrail with additional support brackets for blinds over 48" wide.

9. VALANCE: Crafted PVC based polymer with finish to match slats.

9. ADDITIONAL AVAILABLE OPTIONS: 2 Blinds on 1 Headrail, Hold Down Brackets, Extension Brackets, Cutouts.

2.02 FABRICATION

A. Blind measurements shall be accurate to within + 1/8" or as recommended in writing by manufacturer.

2.04 FINISHES

A. SLAT inish selection from the following: 744 Marble Tile, 745 Sundrenched Cotton, 746 Canvas Tote, 747 Lemon Verbena, 749 Vintage Linen

B. SLAT SUPPORT braided ladders shall be color coordinated with slat. 530 Natural, 830 Almond